



# ROCKDOOR TECHNICAL SPECIFICATION V 7.2

**To main Index ▲**

## VERSION 7.2

### DOOR STYLE SIZES

- 2XGG glazed
- Colonial
- Cosmopolitan glazed
- Elizabethan glazed
- Jacobean glazed
- Grained utility door
- Ayres glazed
- Arcacia glazed
- Carolina glazed
- Carolina geo bar glaze
- Carolina bead geo bar glazed
- 2XG glazed
- Cottage spy view
- Stable spy view split
- Kentucky geo bar glazed
- Kentucky no bar glazed
- Napoli glazed
- Regency glazed
- Cottage view light
- Stable view light split
- Tongue 'N' groove
- Campus
- Double door

### BENEFITS

### ROCKDOOR Cross Section

- Inner Frame
- Door Leaf
- Locks
- Engaging the split follower
- Keep Adustment
- Handle
- Hinge
- Hinge Adjustment
- External Frame
- Coupling Bar and Frame Extenders
- Low Threshold
- PVCu Threshold and Cills
- Gaskets
- Removable Glazing
- How to reglaze a rockdoor
- Toughen Stamp
- Glass Dimensions
- Matching Panels
- Furniture Colours
- Furniture Dimensions
- Safe -T- bar
- Door Closer Adjustment
- Calculating the clear opening
- Security Mesh
- Cylinder Guard
- Double Doors
- Escutcheon and handle relationship
- Lock Option Extras
- Lock Options Explained
- Lock Options Explained 1
- Lock Options Explained 2
- Fixing Instructions

**Maximum efficiency,  
durability and above all  
reliability.**

## ROCKDOOR Cross Section



- High security hinge tested to 250,000 opening & closing cycles.
- High density thermally efficient chemically bonded core.
- Steel security reinforcement.
- Aluminium reinforcement.
- Anodised handle with long lasting high quality finish with double spring action. Anti-drill plate concealed inside handle.
- Cylinder manufactured from self lubricating alloys.
- Press glazed double glazed units with toughened glass manufactured to BS5713.
- Full length multipoint locking.
- High impact flame retardant PVCu.
- High performance low threshold tested to DD171.
- 70mm multi-chambered PVCu outer frame.
- Aluminium reinforcement.
- High performance weather seal.

## INNER FRAME

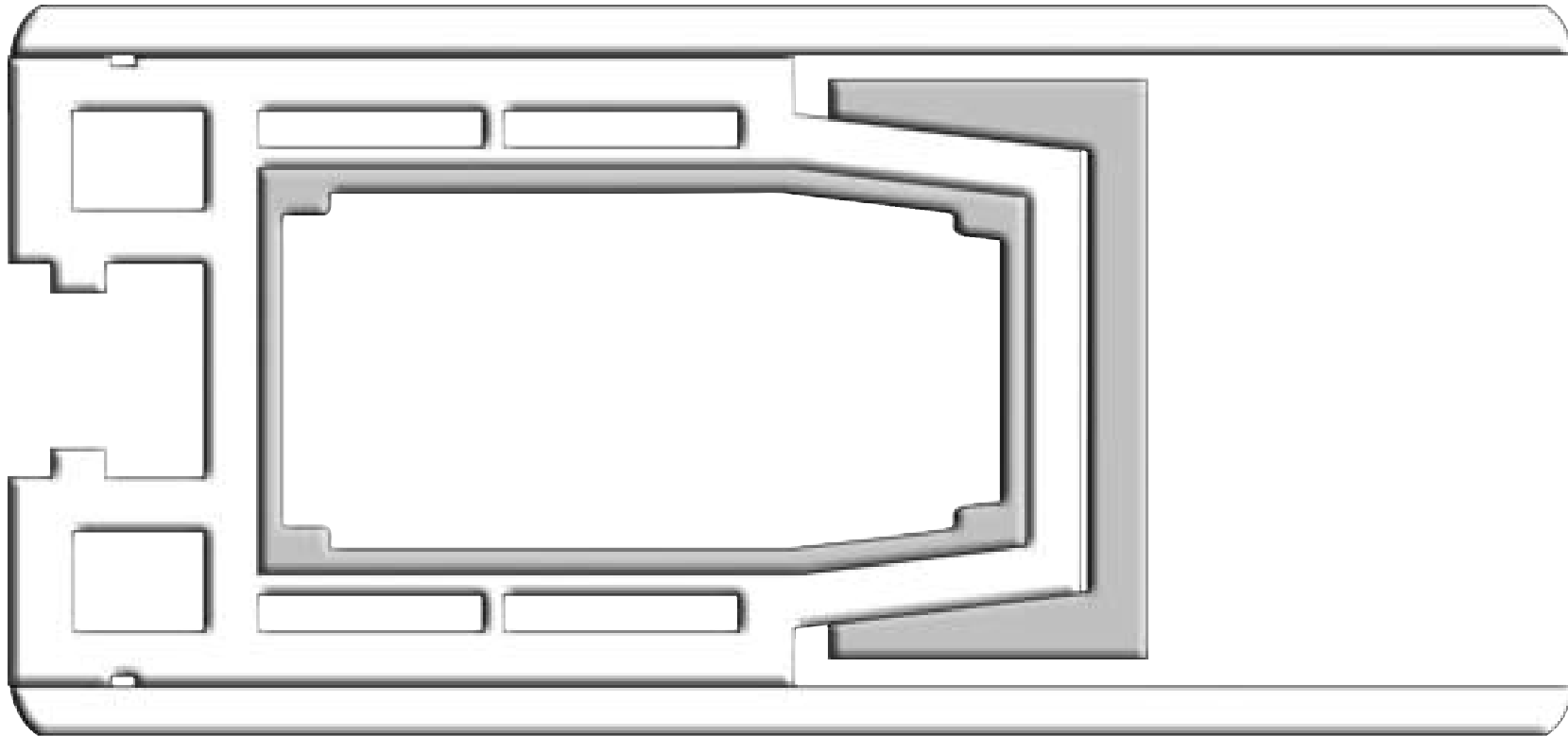

### BENEFITS

The door cannot rot and will not bow or twist, making the door leaf a very solid, stable and durable product.

### Specification

The inner frame is manufactured from extruded PVCu .

The extrusion is reinforced with a specially shaped aluminium bar on the lock side. This bar is totally encapsulated with foam and does not come in to contact with moisture. The profile is also reinforced with a box section aluminium. Providing a secure fixing for the lock and hinges.

The extrusion is cut and welded to the overall size of the door leaf.

### Feature

PVCu is unaffected by moisture and the reinforcement makes the door very rigid.

## DOOR LEAF

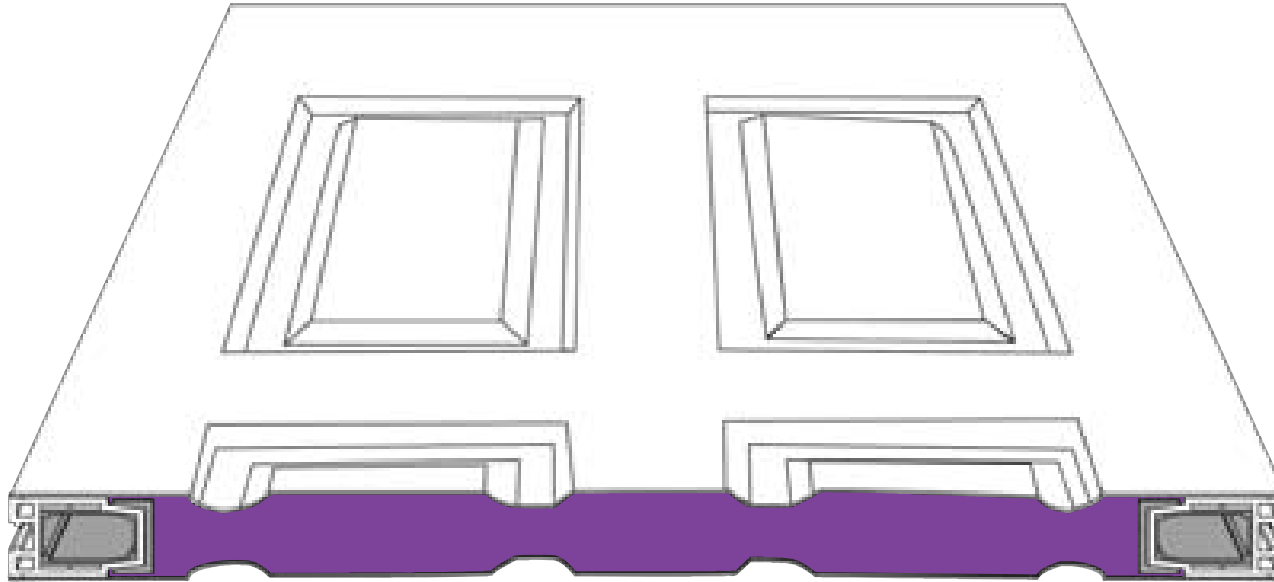

### BENEFITS

The high impact strength and rigidity of the door make it very secure.

The door has been used on various Secure by Design schemes and has also PASSED DD 171 and GGF 6.6.2.

The texture grain hides minor scratches giving the door a much longer aesthetic appeal.

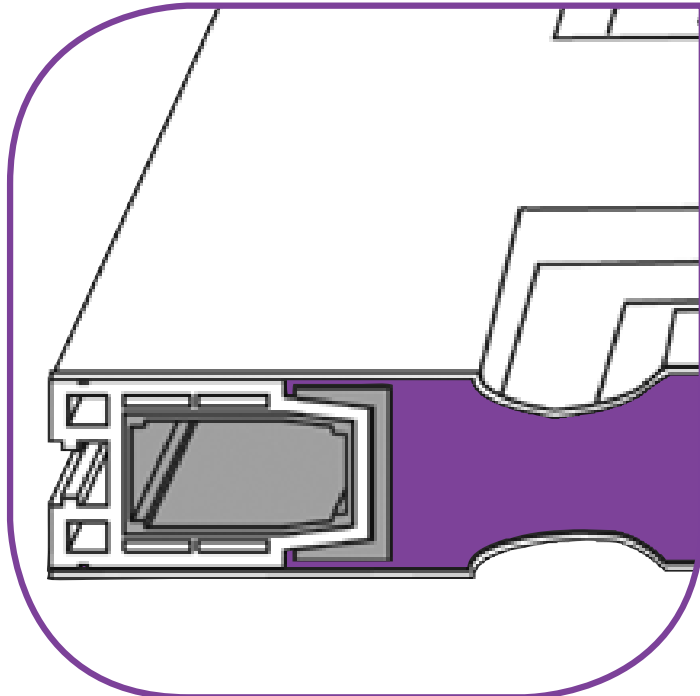

### Specification

The door leaf comprises of the internal frame, CFC Free core and special adhesives.

Two door skins.

The skins are 3mm high impact pvc which has an embossed woodgrain texture. The door skins are bonded to the internal frame with special adhesives which are manufactured to ISO 9002 which when set forms a bond which is stronger than the PVC.

The CFC free core of the door is then injected into the door leaf completely filling all the voids. This reacts with a special bonding agent to form a very strong bond with the door skins making the door very solid and rigid.

### TEST

The door leaf has been subjected to a full cycle test which consisted of the door being subjected to temperatures from -20°C to +60°C. In hourly intervals the door did not delaminate or fail to operate this was carried out continuously for 30 consecutive days.

### Feature

Very strong & needs no maintenance

# LOCKS

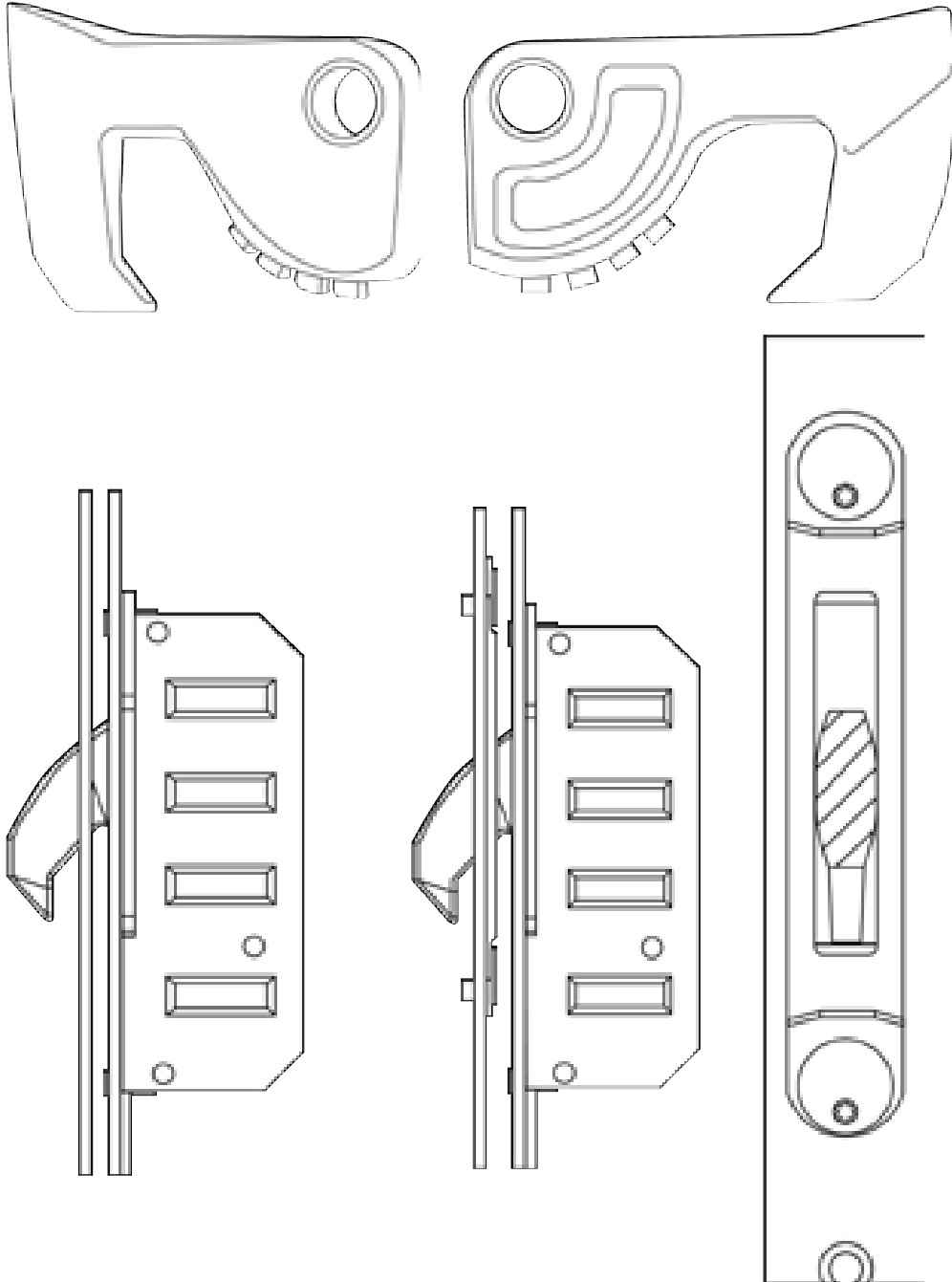

## BENEFITS

The compatibility of the components, ensure total security which has been used successfully on various secure by design projects. Giving peace of mind.

## Specification

The lock use two tapered hooks with a centre dead lock and is manufactured to IS 9002.

The hooked locking tongues penetrate the keep but also hook behind the keep rail to help prevent the prising apart of the door and frame.

The lock mechanism is lever operated and the deadbolt is thrown simultaneously with the locking tongues. The cylinder is locked by one 180 degree key turn.

The locking tongues, deadbolt and latch engage in a steel keep which runs the full length of the frame stile.

All keeps are fully adjustable for regulating operating force and weather seal compression. The minimum adjustment should be +/-2mm.

All exposed steel parts are plated to minimum plating thickness of 8 - 12 microns.

Additional lock models are available on request.

## Feature

The Lock when fitted to a Rockdoor has **PASSED** DD171 and GGF 6.6.2.

Cylinder

It uses five internal pins and a single unrestricted profile. It exceeds CEN1303 requirement for the number of cycles. (Grade 6. 100,000).

## Lock Options

### Option 1

Lever/Handle Operated 2 Hook Lock.

This option allows the opening of the door latch from both the inside and outside. By pushing the lever down, the latch will retract and entry or exit can be gained. To lock the door you must lift the lever up to engage the hooks', then turn the key clockwise to secure the dead lock from either face.

### Option 2

Lever/Handle Operated 2 Hook Lock & additional Yale latch.

This option provides the same functionality as option 1. above. However, the user will require a different key to open and gain access from the outside in addition to the standard door lock.

### Option 3

Lever/Handle Operated 4 Hook Lock.

This option provides the same functionality as option 1 with the added security of two additional hooks.

### Option 4

Key Wind Facility 2 Hook Lock.

No handles are supplied; the hooks and latch are engaged and disengaged by twisting the key in the cylinder from the outside & twisting the thumb turn from the inside operating both the latch & hooks the latch. You will need the use of a key to enter and exit the property using this lock option. However, you will need to provide a method for pulling the door too, for example a door knob.

### Option 5

Key Wind Facility 2 Hook Lock & additional Yale latch.

This option provides the same functionality as option 4. above. However, the user will require a different key to open and gain access from the outside in addition to the standard door lock.

### Option 6

Key Wind Facility 4 Hook Lock.

This option provides the same functionality as option 4 with the added security of two additional hooks.

### Option 7

This option is specifically for stable doors only therefore it may not be fitted to standard Rockdoor or one of the options 1-6 may not be fitted to a Stable Door.

Additional extra's available to:

#### Option 1,2 & 3

Split follower, this function operates much the same as a lever pad operation in that the door, although a handle is fitted, may only be opened from outside with the use of a key giving a slam shut situation.

#### Option 3,4 & 5 (only)

Key/Key cylinder, this only allows the door be opened internally and externally with the use of a key.

#### Option 3,4 & 5 (only)

Split ball handle (inside only), which allows the operation of the latch without using the thumb turn or key internally.

## ENGAGING THE SPLIT FOLLOWER

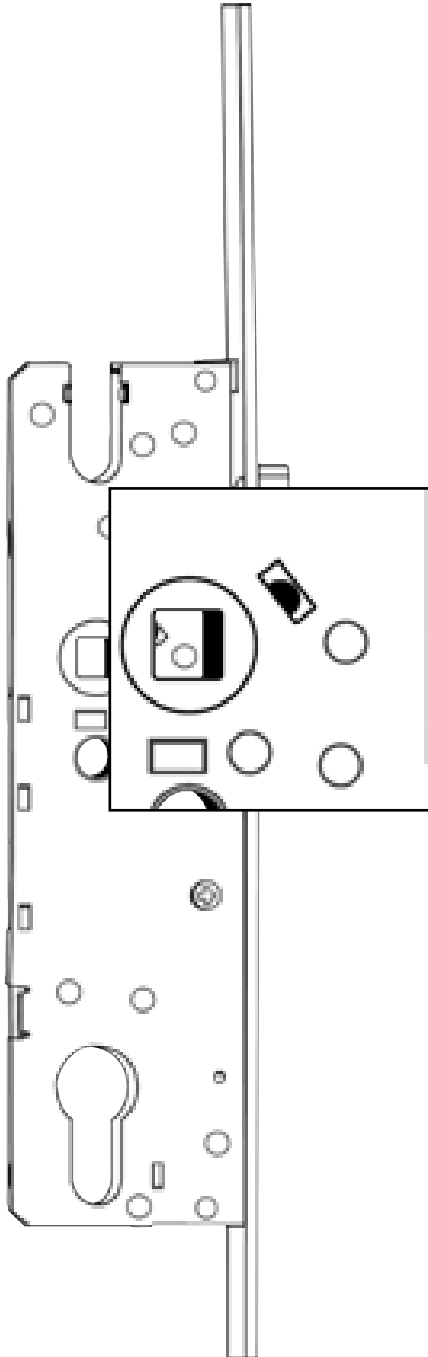

### Engage The Split Follower Lock Follow The Instructions Below:

- Remove the lock from the sash
- Locate the 45° angled aperture in the side plate of central gearbox, the shot is adjacent to the handle spindle square drive.
- You will see a small black split pin within the internal mechanism.
- Using a small flat bladed screwdriver (7mm) carefully push the split pin through to finish flush with the side adjacent with the flat edge
- This will engage the split follower lock function.
- Re-install the lock.
- Fit the split spindle set.
- Fit handle set.
- Check Lock / Handle operation.

### User Instructions Split Follower Lock

#### EXTERNAL OPERATION

Locking is achieved by lifting the external handle, which extends the central deadbolt and engages the locking hooks, and then turning the key 360° which will deadlock the mechanism.

Unlocking is achieved by turning the key 360° and depressing the external lever, this retracts the central deadbolt and locking hooks, a further half turn of the key will retract the centre latch allowing entry to the property.

#### INTERNAL OPERATION

Locking is achieved by lifting the internal lever, which extends the central deadbolt and engages the locking hooks, and then, turning the thumbturn 360° which will deadlock the mechanism.

Unlocking is achieved by turning the thumbturn or key 360° and depressing the internal lever, this retracts both the central deadbolt and locking hooks allowing exit from the property.



# HANDLE

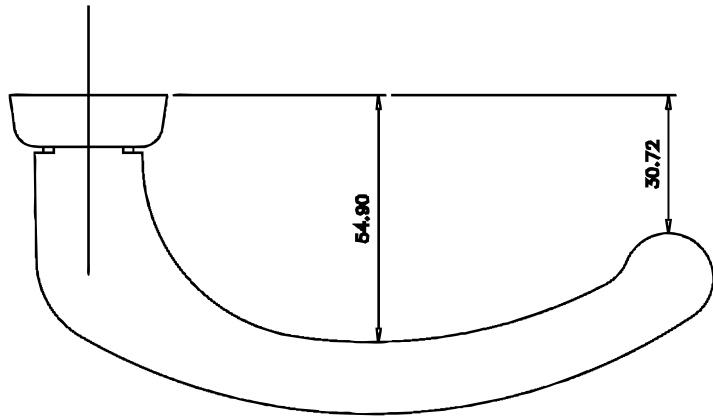

## BENEFITS

Even after consistent use the handle will still perform as well as when it was new.

## Specification

The ROCKDOOR euro handle is manufactured from Aluminium in accordance with DIN 1725. It's handle is spring loaded and comes with a concealed anti - drill plate. It has three internal through fixings. The lever is anodised to 10 microns. Self lubricating.

## TEST

The handle has been successfully cycle performance tested to 200,000 cycles problem free and has achieved 1000 hours in a salt spray test.

Available colours-  
A SATIN CHROME  
B POLISHED CHROME  
C BRIGHT BRONZE  
D POLISHED GOLD  
E BRILLIANT WHITE  
F MIDNIGHT BLACK

## Feature

Stylish robust handle.

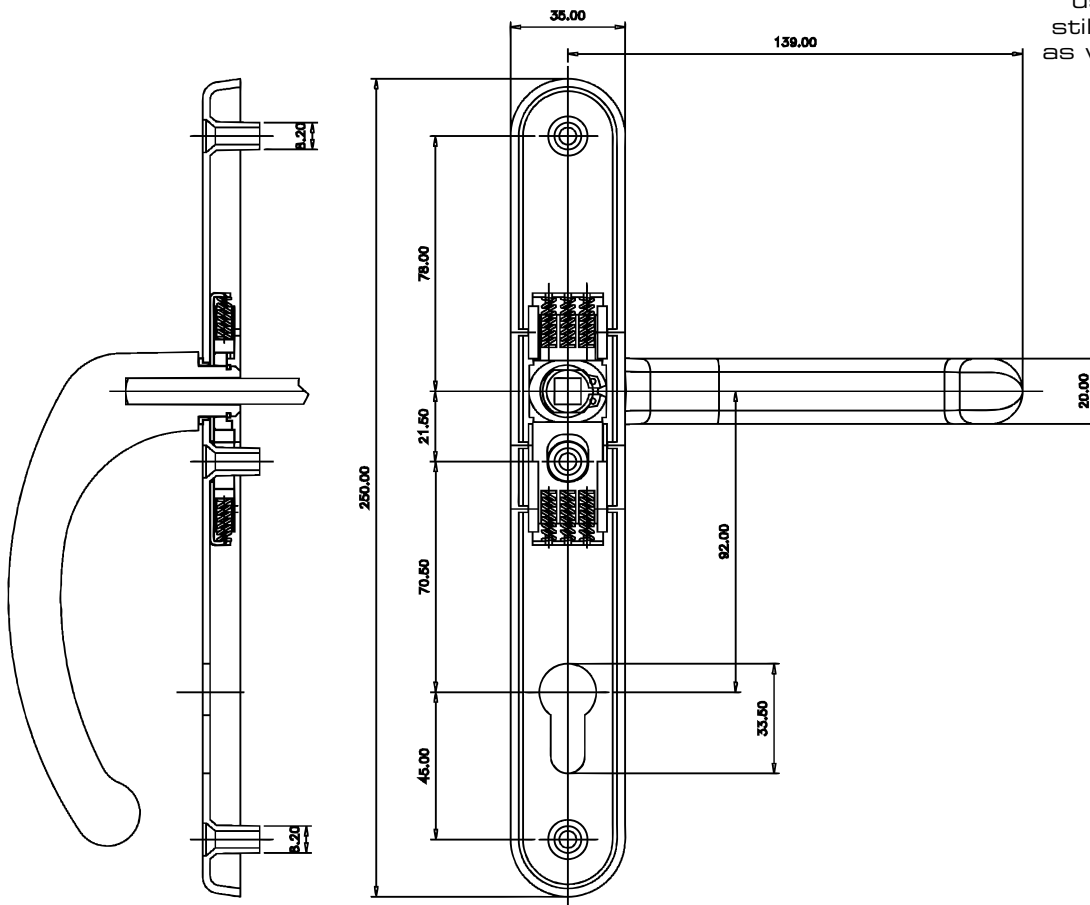

# HINGE

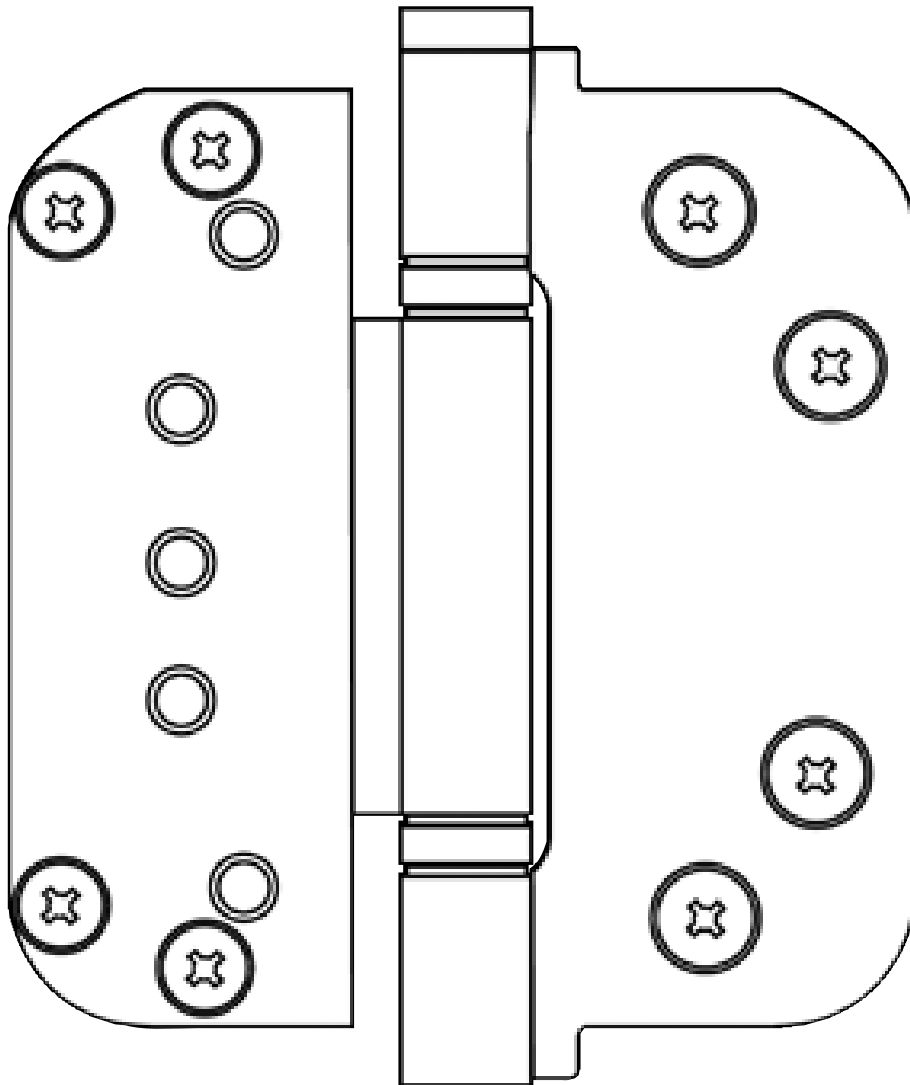

## BENEFITS

The easy adjustment makes it easier to install a rockdoor to a required standard.

## Specification

The hinge is manufactured from low maintenance materials and is adjustable in 3 directions. The hinge has maintenance free bearings and three hinges will carry 120 kg in weight.

It has been tested through 25,000 continuous opening / closings without any maintaining with 30% overload showed no measurable wear.

**PASSED** DD171 - REPORT NO 261/005209  
**PASSED** GGF 6.6,2 - REPORT NO DR97-003

The top hinge is fastened to the polypropylene hinge block. The block should be fastened to brickwork on installation for strength.

Available colours- WHITE  
BLACK  
GOLD  
SILVER  
BROWN

## Feature

The hinge is fully adjustable in three directions. And requires no maintenance.

Adjustment of- HEIGHT +/- 3mm  
SIDE +/- 2mm  
DEPTH 0 - 4mm

## HINGE ADJUSTMENT

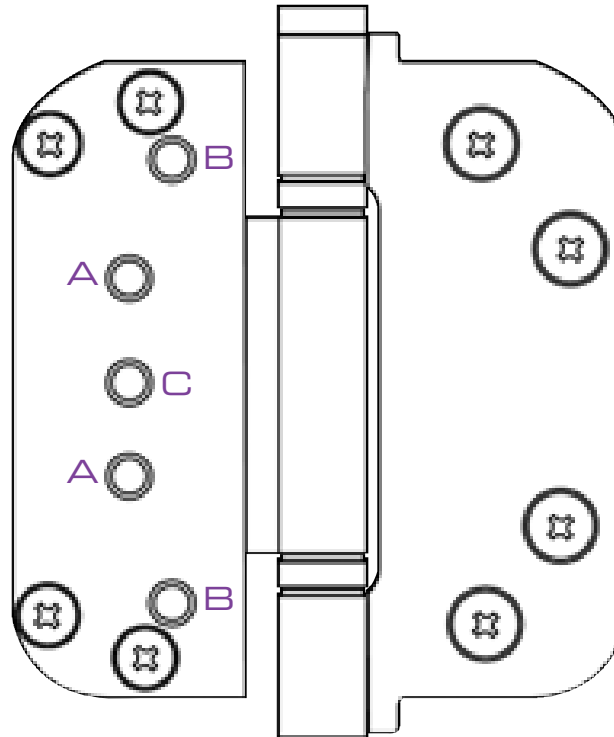

Please note: each door-set is factory set with a 4mm air-gap to both sides of the door and to the head within the frame. Consideration should be given to maintaining this air-gap to ensure optimum performance and correct operation of the door. The air gap to the lock side must take priority when adjusting to ensure it is 4mm, the full length of the door.

### 1. Vertical air gap adjustment

By releasing the two 4mm grub screws "A", the door can be adjusted vertically up or down to lift and drop the door sash within the outerframe. This allows the air gap at the top and bottom of the door sash to be increased and decreased.

There are guide lines stamped on the hinge at position "C" to assist with adjustments.

Care must be taken not to raise the door too high or too low as this will affect the performance of the weather seal on the low threshold.

The two grub screws "A" also allow the door sash to be adjusted forwards and back. This adjustment will increase or decrease the pressure on the outerframe's Q-Lon gasket.

### 2. Horizontal air gap adjustment

By releasing the two 4mm grub screws "B", the door sash can be adjusted to the left and right within the Outerframe. This allows the air gap on the hinge and lock side of the door to be set. **The air gap on the lock side must be set to 4mm.**

There is adequate adjustment on each of the three-way hinges for setting up the door sash correctly within the outerframe.

However, the hinge adjustment cannot compensate for a door frame that is fixed out-of-square, with a bowed frame or with a twist from front to back.

Care must be taken to pack the frame securely into the opening, making sure that all faces are square and plumb.

Caution: Do not over-tighten or over-adjust the grub screws.

## EXTERNAL FRAME

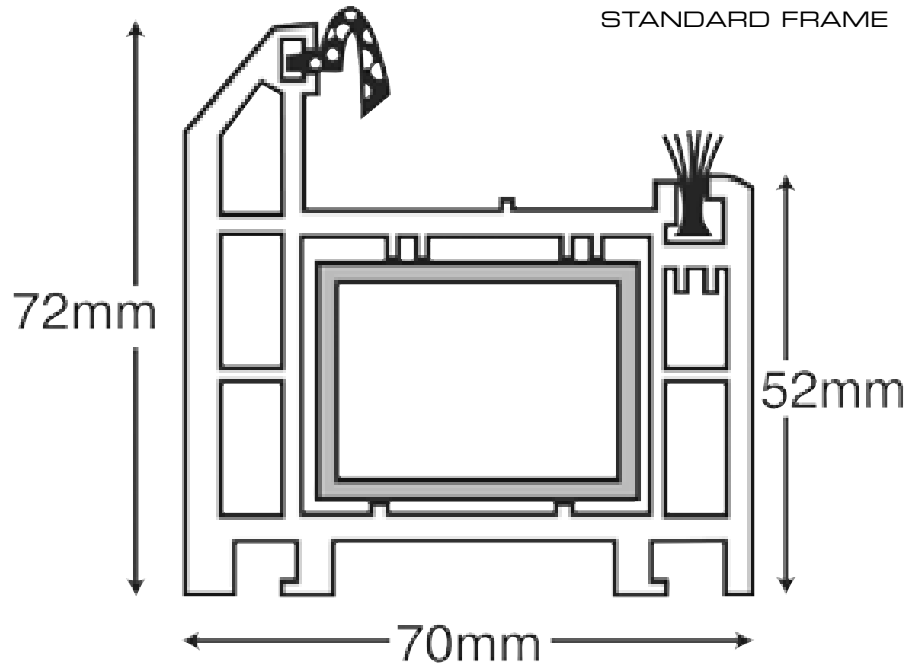

### BENEFITS

The specification of the door and frame ensure that they perform together for a minimum of ten years.

### Specification

The external frame is manufactured from extruded PVC which is reinforced with aluminium. The frame and door have a double weather seal which has passed DD171. It has also passed GGF 6.6.2 for security. Q-lon gasket is standard.

### The External

The external frame holds a kitemark to BS7413 and is also BBA approved. It also has a certificate for ISO 9001 for design and ISO 9002 for Manufacturing procedures.

### Feature

PVC is unaffected by moisture.

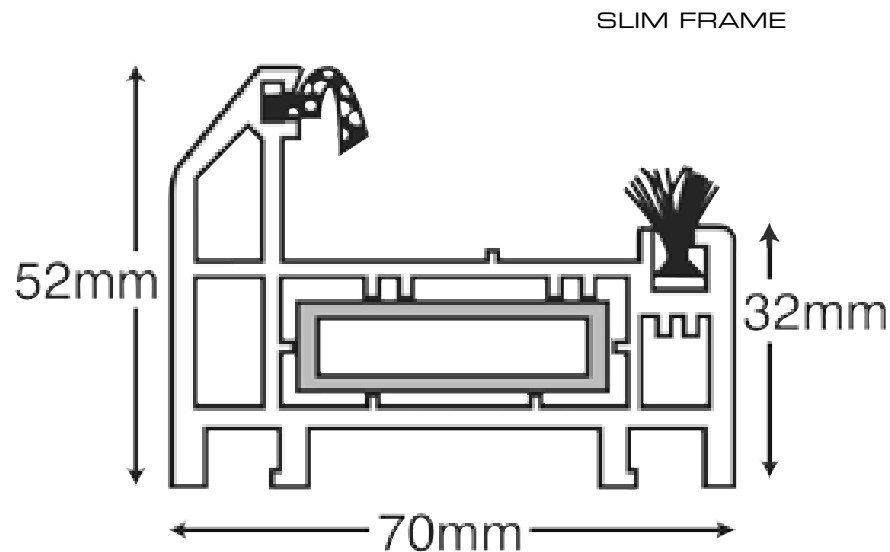

## COUPLING BAR & FRAME EXTENDERS

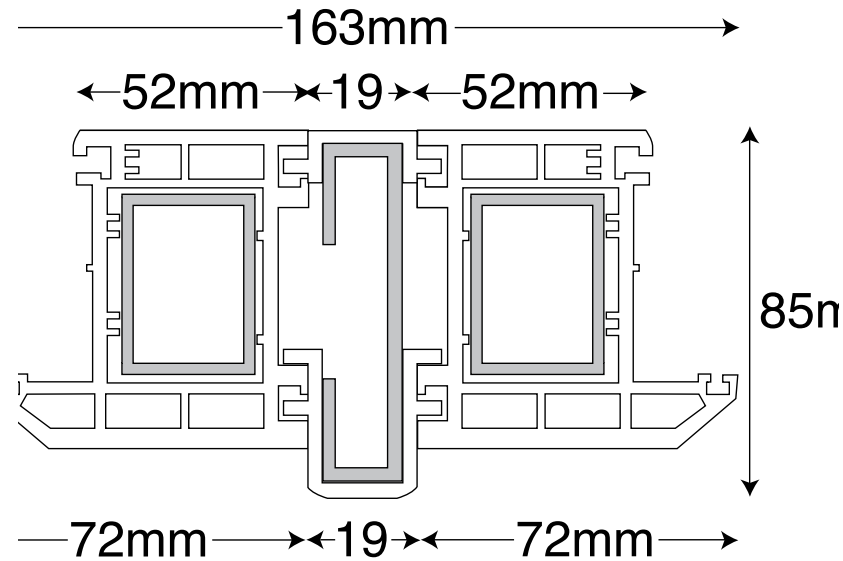

### BENEFITS

The steel reinforcement stops the door from springing either when the door is slammed or under forced entry.

### Specification

The coupling bar comprises of two extruded PVCu profiles which fasten round the galvanised steel reinforcement.

### Feature

Galvanised steel reinforcement for strength and security.

## frame extenders

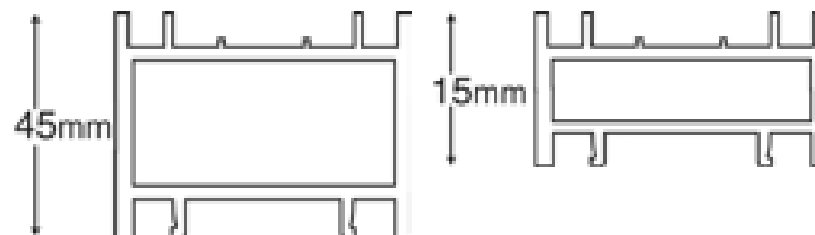

# LOW THRESHOLD

Inward opening door  
Low threshold specifications

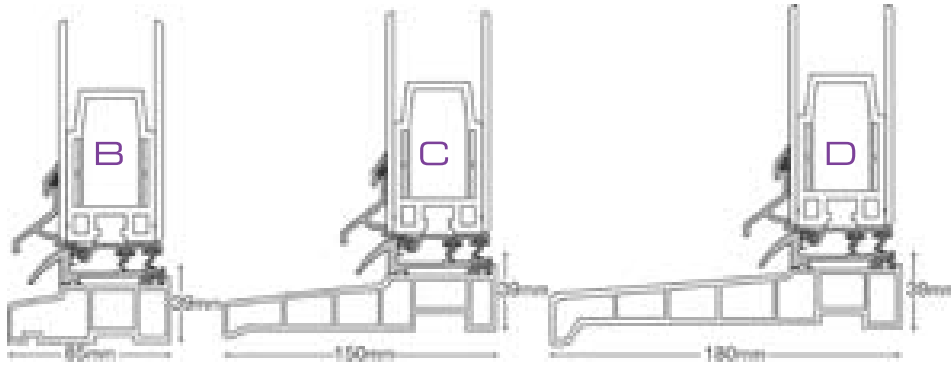

Inward opening door  
Low threshold specifications

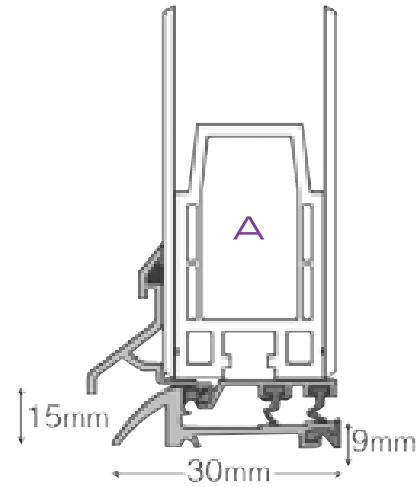

Outward opening door

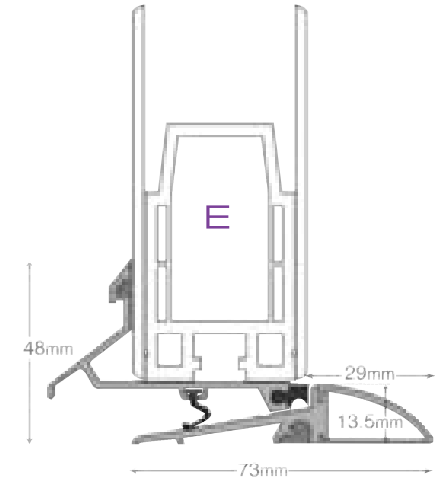

Outward opening door

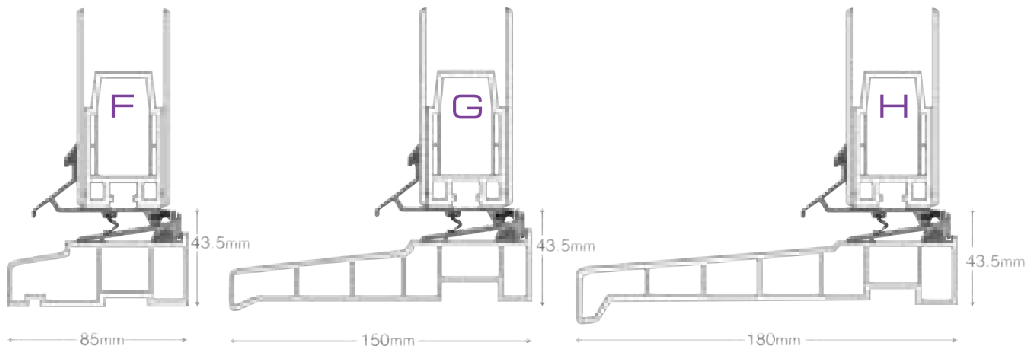

## BENEFITS

Easy access with a high performance weather seal.

## Specification

The threshold is manufactured from hardened aluminium to BS 1474 and is anodised to a minimum of 15 to 25 microns to BS 3987. Powder coatings 60 to 80 micrometers to BS 6496. All seals and gaskets are to British standards.

## TEST

The threshold has been tested to 1000 pascals of moisture and did not leak.

Colours available- Polished Gold  
Anodized Satin  
Bright Bronze

## Feature

Aluminium Low Threshold with a continuous door seal.

# PVCU THRESHOLD & GILLS

Inward opening door  
PVCu threshold

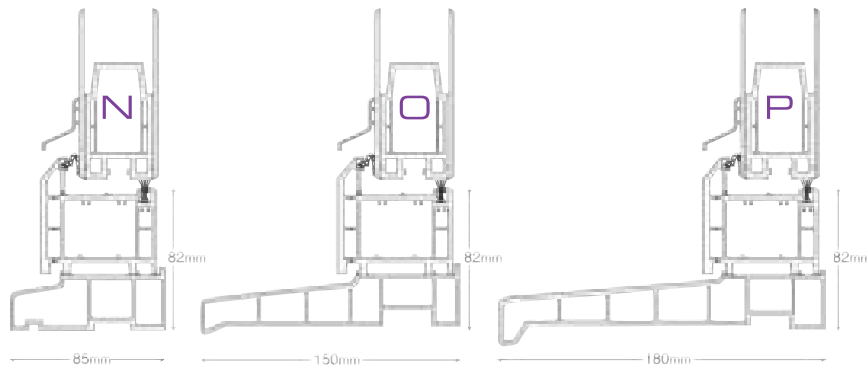
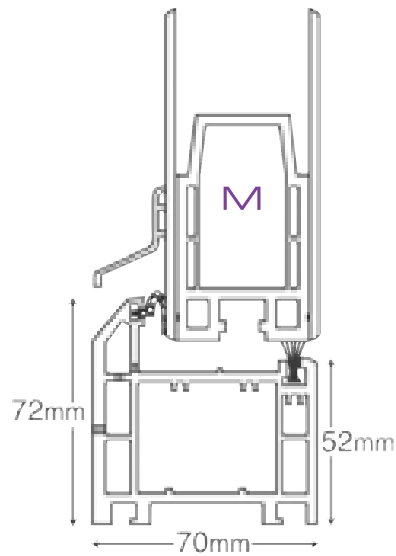
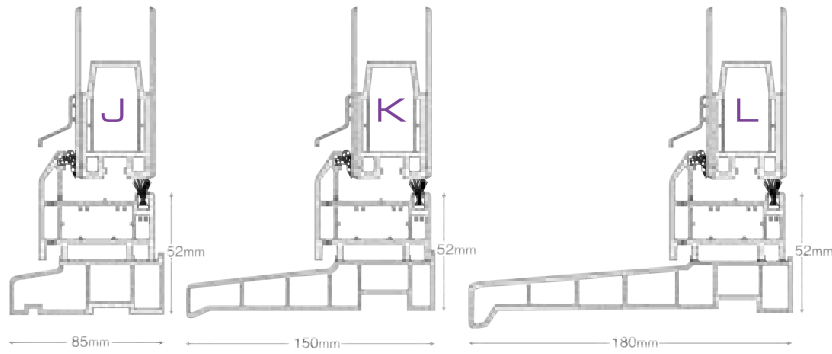
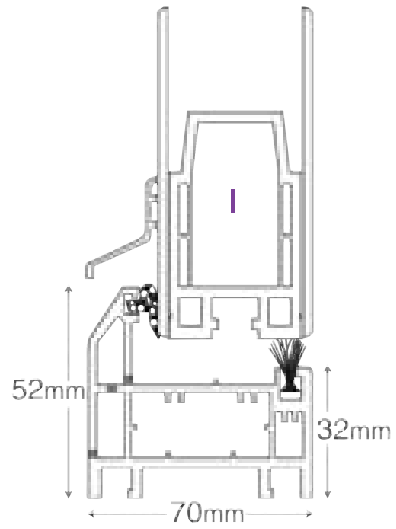

Outward opening door

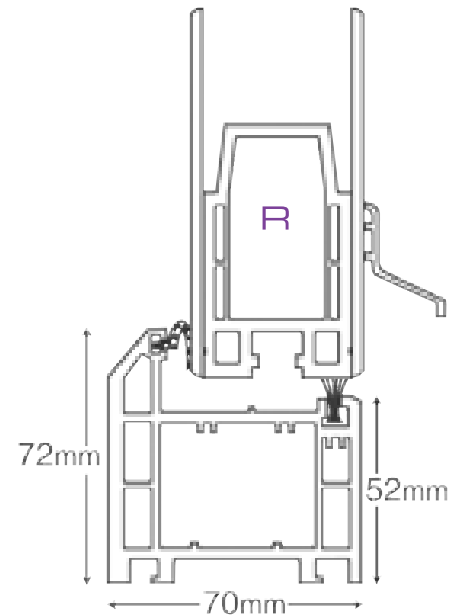
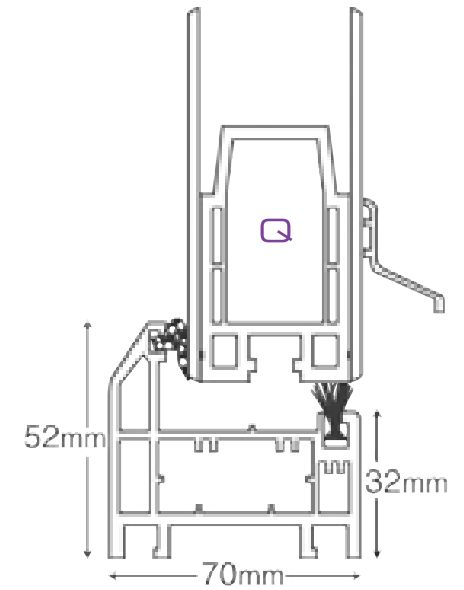

# REMOVABLE GLAZING

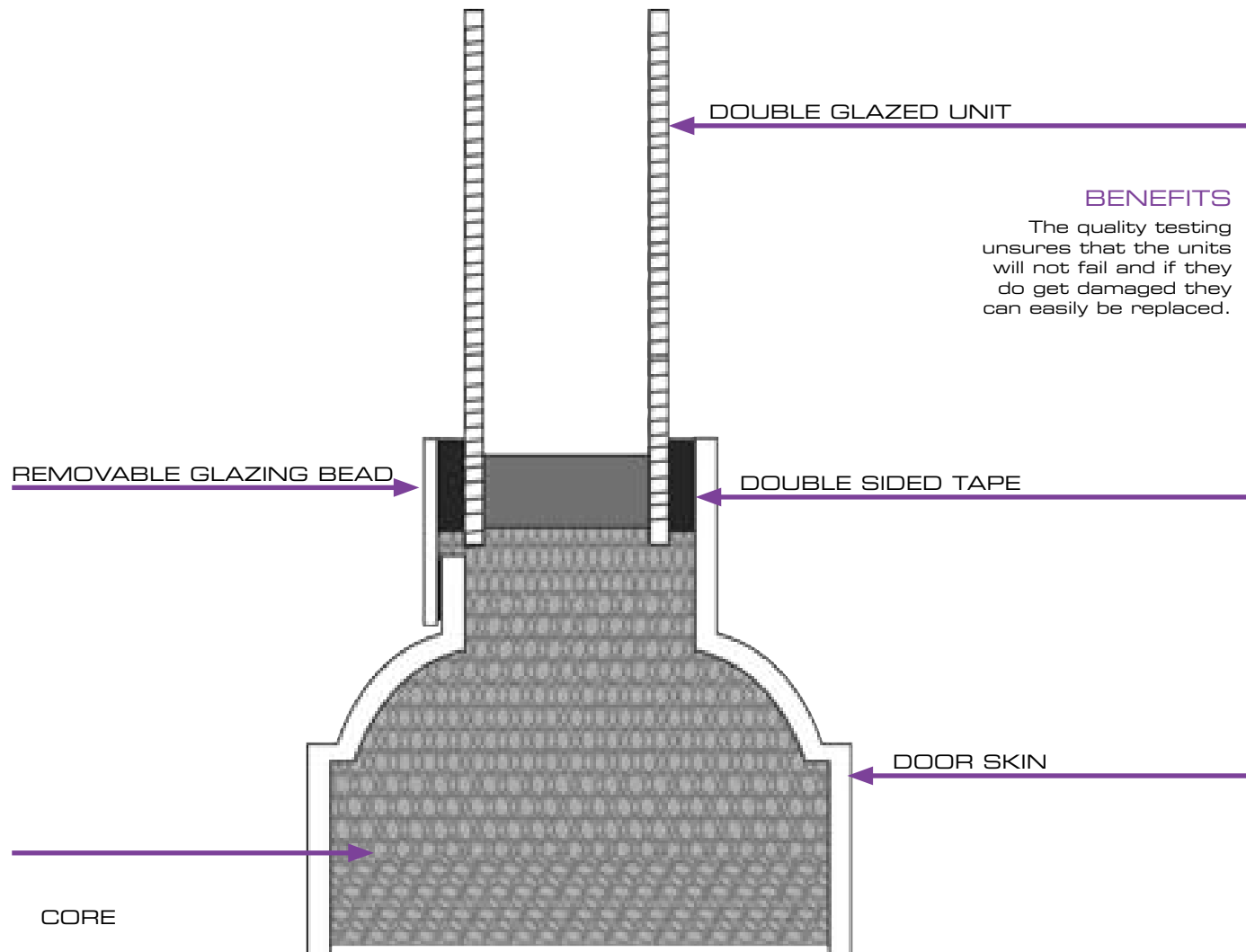

## BENEFITS

The quality testing ensures that the units will not fail and if they do get damaged they can easily be replaced.

## Specification

ROCKDOOR have two types of glazing Press Glazing & Bead Glazing. Bead Glazing enables the double glazing unit to be replaced if it gets damaged. Press Glazing is even more secure because the units cannot be removed. All double glazed units have passed **BS 5713**.

**TAPE - WEATHERING AND UV RESISTANCE**  
6 months of UV + condensation @ 23  
**PASSED**

**THERMAL MOVEMENT SHEAR TEST**  
2 hour @ 70°C then 4 hours @ 23  
four cycles per day continued for a month.  
**PASSED**

**PEEL ADHESION @ 23oc** 17 N/25mm

**SHEAR @ 23oc** 30 N/625mm<sup>2</sup>

**TEMP RANGE - 40 TO 100 °C**

## Feature

Bead Glazing Rockdoors can be reglazed on site.



## HOW TO REGLAZE A ROCKDOOR

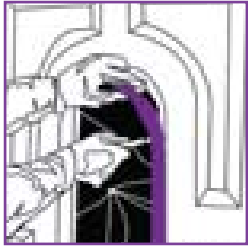

**1.INSIDE:** Cut around the bead using a craft knife with the blade extended to 35mm, making sure to get the blade between the bead and the door skin. The bead will then become free to remove. Remove the bead.

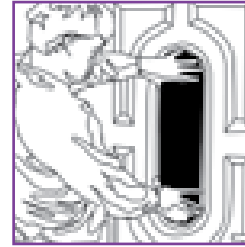

**4.INSIDE:** Clean off all the double sided tape making sure that both edges are free from dirt or grease. A wipe with a solvent might be required. Apply new double sided tape to the inside of the rebate on the door.



**2.OUTSIDE:** Cut between the glass edge and the door skin edge all the way round using the craft knife with the blade extended to 25 mm.

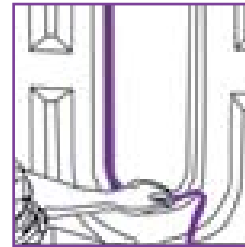

**5.INSIDE:** Remove the backing from the double sided tape on the door. Wipe the glass making sure it is free from dirt or grease. Offer the glass up to the door and apply pressure.

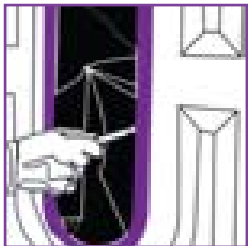

**3.INSIDE:** Cut between the glass and the door skin using the craft knife with the blade extended to 15 mm. The glass can now be removed.

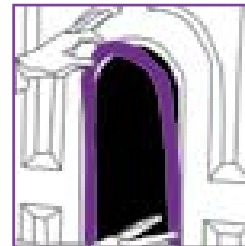

**6.INSIDE:** Remove the backing from the double sided tape on the new bead and offer it to the door. When it is in the correct position apply an even pressure all the way around the bead. Silicone all the way round the edge of the glass on both sides of the door.

# GASKETS

Name: **Q-LON  
DOOR SEAL**



CODE R899 BLACK  
R498 WHITE

Name: **BRUSH PILE  
SECONDARY SEAL**



CODE R801 GREY

**THRESHOLD GASKET**

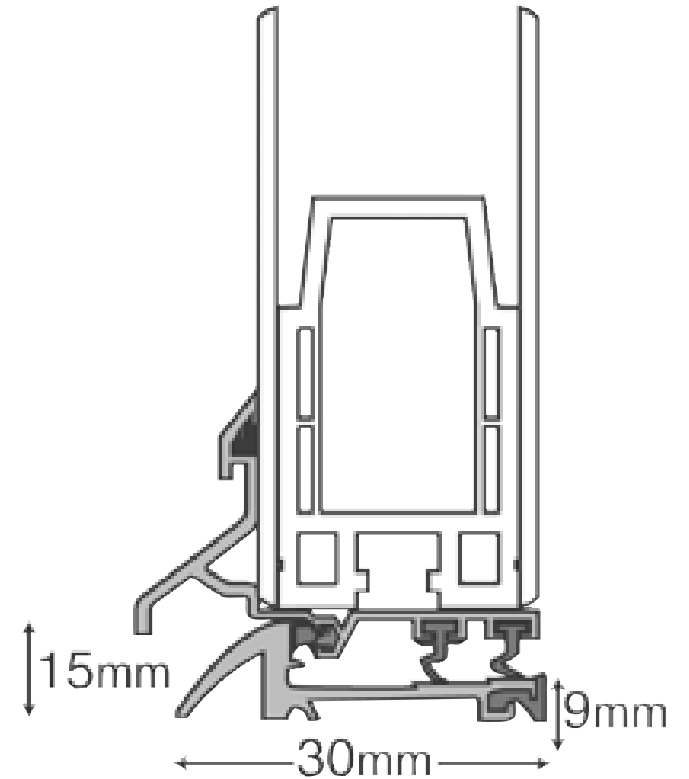

Name: **GLAZING GASKET**



CODE R461 BLACK  
R461A WHITE

Name: **STABLE CENTRE SEAL**



CODE R856A BLACK



EXTERNAL  
CODE R149B



CENTER  
CODE R149A



INTERNAL  
CODE R149

# TOUGHEN STAMP

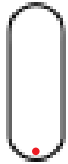

Arcacia T1  
246x668

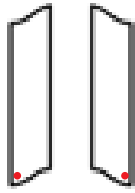

Cos  
181x792

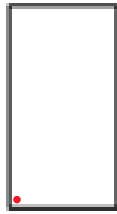

2XG  
535x910



2XGG top  
510x890

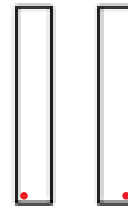

Jacobean p/b  
185x870

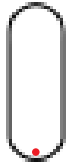

Arcacia T2  
207x635

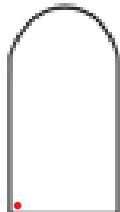

Kentucky p (T1)  
560x912

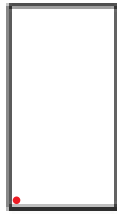

2XG p/b  
495x875



2XGG top p/b  
470x852

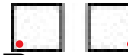

Regency  
190X138



Stable Spy  
150x300



Ayres  
511X1010

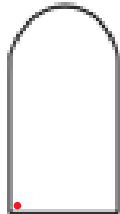

Kentucky p/b (T2)  
516x875

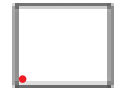

2XGG btm  
510x490



Elizabethan  
195x455



Stable Spy p/b  
114x255



Carolina T1  
560x275



2XGG btm p/b  
470x455

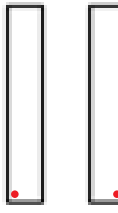

Jacobean  
220x910

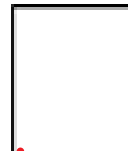

Stable View  
485x625



Carolina T3 Flat  
495x225

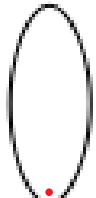

Napoli  
365x862

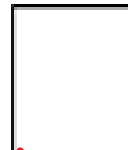

Stable View p/b  
440x580

● Position of Toughen Stamp

## GLASS DIMENSIONS

Door Style	Glazing	Template	O/A Size (MM)	Aperture (MM)		Thickness (MM)	Double Glaze	Triple Glaze
				Width	Height			
Elizabethan	Press	No	195 x 455	159	419	22	Yes	No
Arcacia	Press	Yes	246 x 668	208	630	22	Yes	No
Arcacia	Press Bead	Yes	207 x 632	182	604	24	Yes	No
Carolina Geo Bar	Press	Yes	560 x 275			22	Yes	No
Carolina (T2)	Press	Yes	490 x 225	452	192	22	Yes	No
Carolina (T2)	Press Bead	Yes	490 x 225	452	192	24	Yes	No
Regency	Press	No	198 x 147	157	105	22	Yes	No
Regency	Press Bead	No	198 x 147	157	105	24	Yes	No
Jacobean	Press	No	220 x 910	180	866	22	Yes	No
Jacobean	Press Bead	No	188 x 875	155	842	24	Yes	No
2XG	Press	No	535 x 910	489	866	22	Yes	No
2XG	Press Bead	No	495 x 875	462	842	24	Yes	No
Stable/Cottage View	Press	No	485 x 625	436	576	22	Yes	No
Stable View	Press Bead	No	440 x 580	410	550	24	Yes	No

Door Style	Glazing	Template	O/A Size (MM)	Aperture (MM)		Thickness (MM)	Double Glaze	Triple Glaze
				Width	Height			
Stable/Cottage Spy	Press	No	150 x 300	109	252	36	No	Yes
Stable Spy	Press	No	114 x 255	184	226	35	No	Yes
Kentucky	Press	Yes	560 x 912	508	867	22	Yes	No
Kentucky	Press Bead	Yes	516 x 875	482	840	24	Yes	No
2XGG (Top)	Press	No	510 x 890	466	846	22	Yes	No
2XGG (Bottom)	Press	No	510 x 490	466	448	22	Yes	No
2XGG (Top)	Press Bead	No	470 x 852	438	818	24	Yes	No
2XGG (Bottom)	Press Bead	No	470 x 455	438	422	24	Yes	No
Campus	Press	No				22	Yes	No
Campus	Press	No	185 x 630	148	590	24	Yes	No
Cosmopolitan	Press	Yes	181 x 792	145	678 665 678	28	No	Yes
Ayres	Press	Yes	511 x 1008	462	752 961 752	30	No	Yes
Napoli	Press	Yes	365 x 862	320	819	14	Yes	No

## MATCHING PANELS

Panel Style	Minimum Width	Maximum Width	Minimum Width Including Standard Frame & coupling	Maximum Width Including Standard Frame & coupling
Single Moulded Panel To match Jacobean, Windsor, Carolina, Colonial	332	412	467	547
Double Moulded Panel To match Jacobean, Windsor, Carolina, Colonial	661	890	796	1025
Moulded Panel To match Stable, cottage	600	890	735	1025
Flush Grain Panel	100	890	235	1025

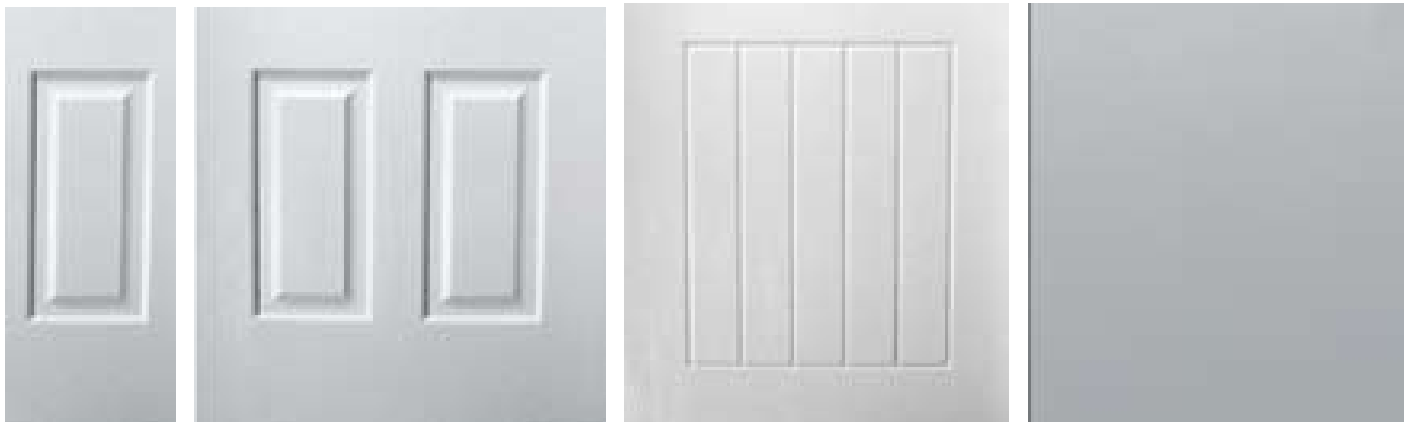

# FURNITURE COLOURS

## Furniture

	Colour									
Lever /Lever Handle	✓									Polished Gold
Lever /Pad Handle	✓									Anodised Gold
Hinge	✓									Brass
Letter Plate	✓									Polished Chrome
Slim Line Letter Plate (For Side Frames)		✓								Satin Chrome
Rockdoor Yale Latch	✓									Bright Bronze
Urn Knocker	✓									Midnight Black
Spy Hole										Brilliant White
Large Lions Head Knocker										
Small Lions Head Knocker										
Scroll Knocker										
Escutcheon										
Stable Slide Bolt	✓									
Stable Centre Seal	✓									
Threshold	✓									
Drip Rail	✓									
Centre Knob										
Numerals	✓									
Thumbturn										
Cylinders										
Safe T Bar										
Double Door Centre Seal	✓									



# FURNITURE DIMENSIONS

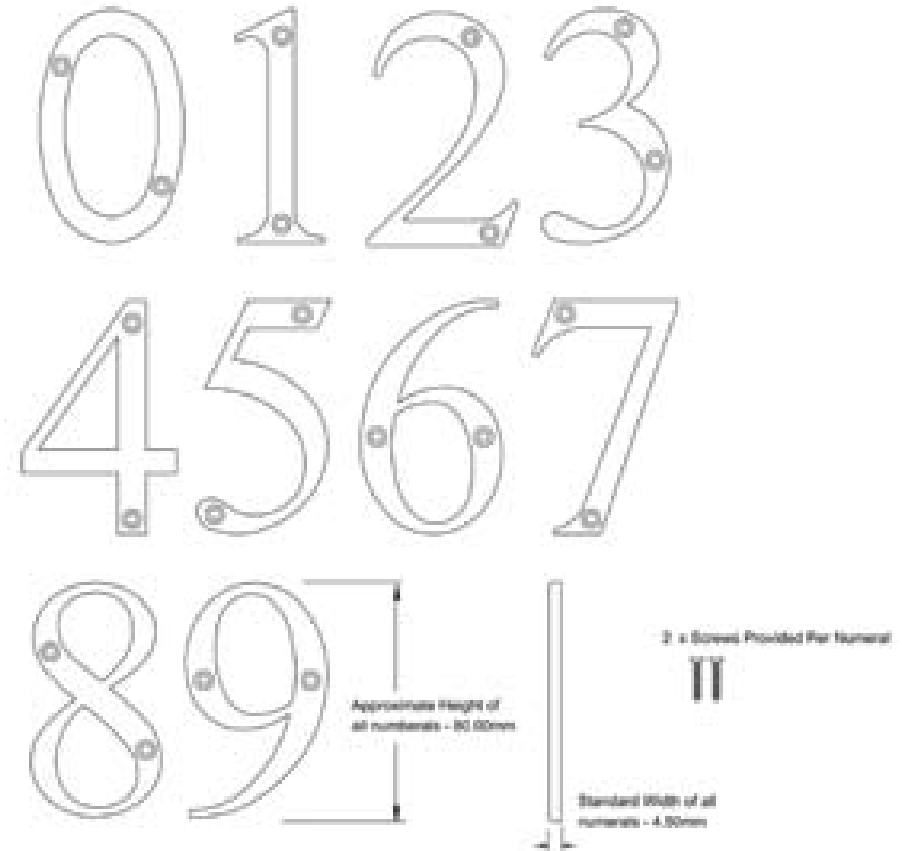
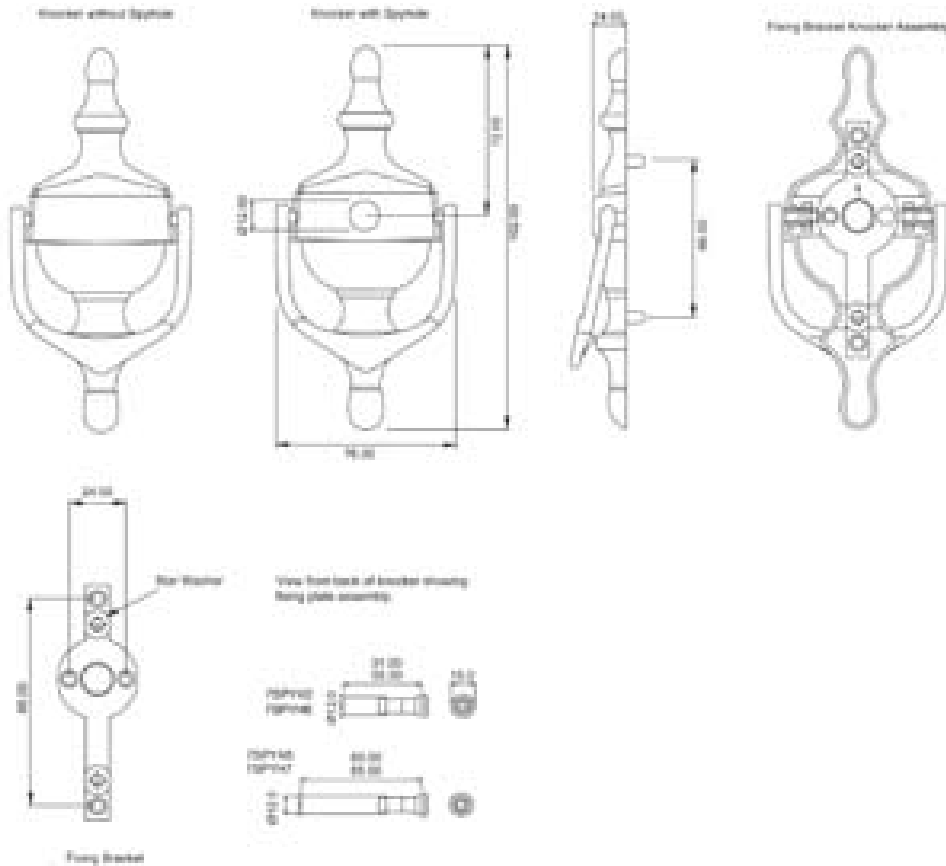

## Specification

Materials conform to BS7412 clause 4. Die cast alloy to BS EN 12844. Steel parts to BS970 Part 1  
Corrosion Resistant BS EN 1670: 1998 - 240 Hour (Very High) in acceptance to Clause 5.7 as specified in BS7412.  
Solid die cast design giving a substantial feel and reliable performance.  
Available with spy-hole to meet safety and security needs.  
Market-leading secret fix system, no internal screws, fast and secure installation.  
Combines perfectly with the rockdoor product range: letterplates, door handles and numerals.  
Choice of colours: Satin Chrome. Polished Chrome. Bright Bronze. Polished Gold. Brilliant White. Midnight Black  
Meets the requirements of BSEN 1670: 1998 for corrosion resistance - 240 hours of corrosion resistance.

## Specification

Materials conform to BS7412 clause 4. Die cast alloy BS EN 12844. Steel parts to BS970 Part 1.  
Corrosion Resistant - BS EN 1670: 1998 - 240 Hours (Very High) in acceptance to Clause 5.7 as specified in BS7412.  
Choice of colours: Satin Chrome. Polished Chrome. Bright Bronze. Polished Gold. Brilliant White. Midnight Black  
Die-cast product - the screw position remain constant, easy to fix.  
Colour co-ordinated screw provided with each numeral.  
Meets the requirements of BSEN 1670: 1998 for corrosion resistance - 240 hours of corrosion resistance



## SAFE -T- BAR

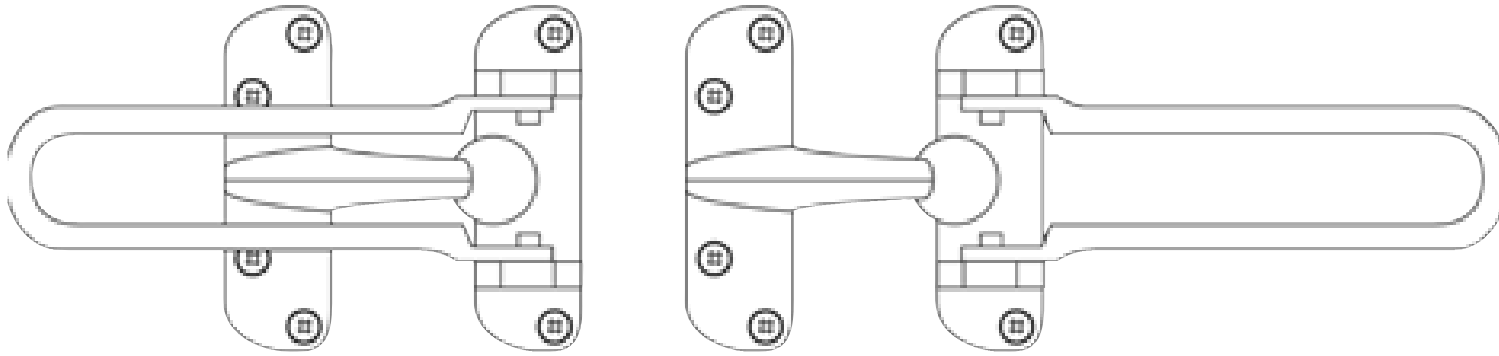

### BENEFITS

Occupants can see who it is at their door before they let them in.

### Specification

The safe-T-bar is made from cast steel then electro brassed. This is fastened directly into the aluminium reinforcement for total strength. Safe-T-bar are not fitted as standard.

### Feature

The Rockdoor restrictor is designed to limit the door opening prior to allowing entrance to visitors. It is easily applied and released only when the door is closed.

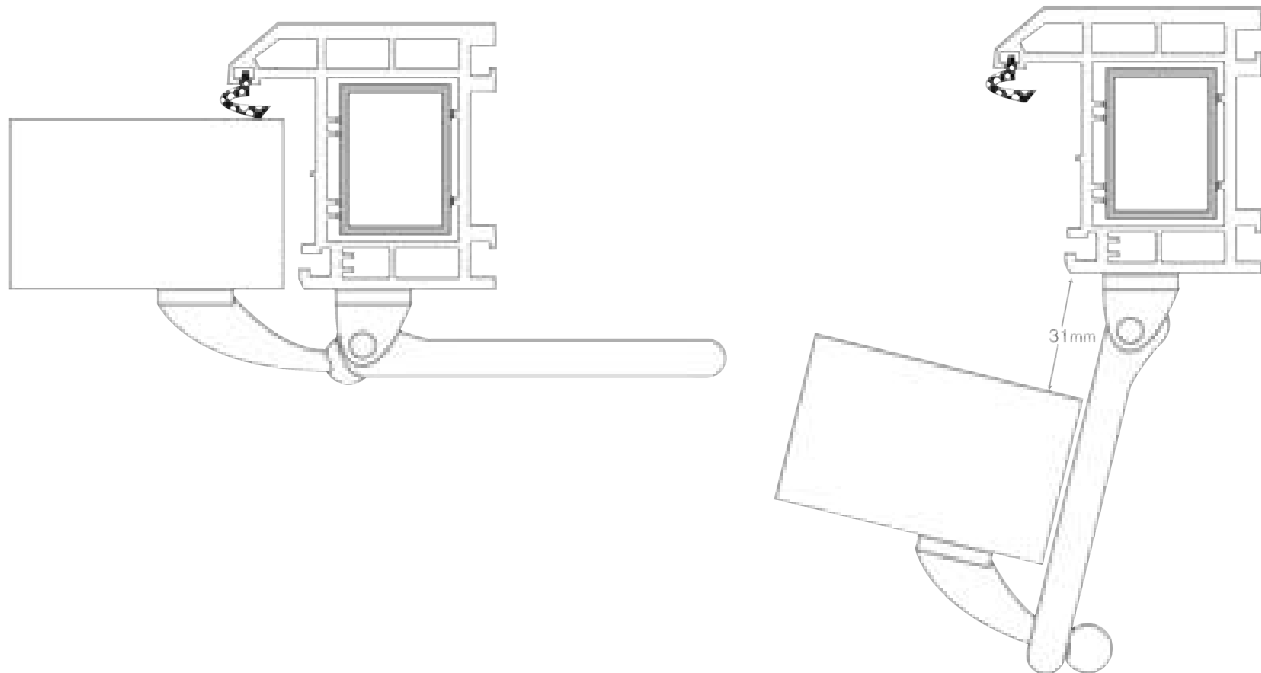

**AVAILABLE IN  
BRASS AND POLISHED CHROME**

## DOOR CLOSER ADJUSTMENT

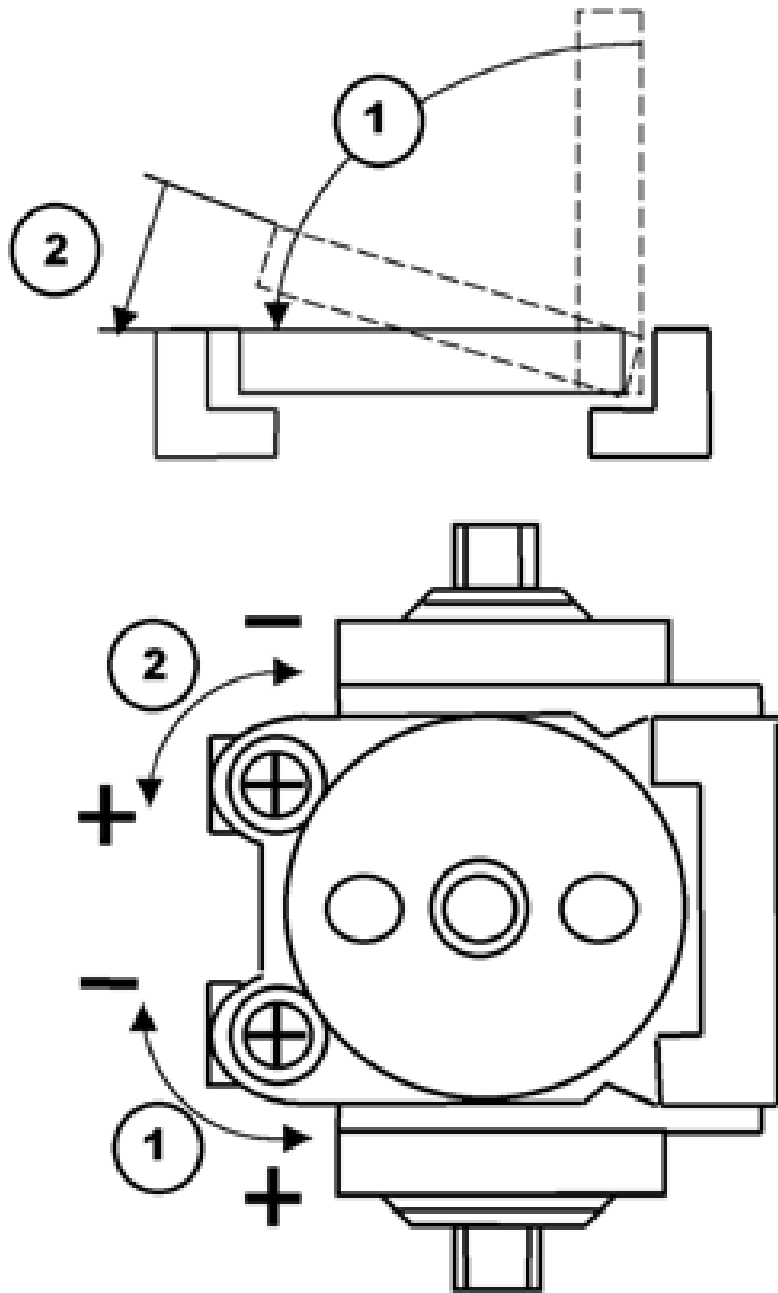

### Door Closer Adjustment

Door closers are factory set although it is possible to control the closing action.

Turning the top screw anticlockwise will increase the closing force action of the door.

Turning the top adjustment screw clockwise will reduce the closing force action of the door.

The door closer has a anti slam function in that it is possible to slow down the action for the last few inches before it closes by turning the bottom screw clockwise, or if necessary to speed the action up by turning the bottom screw anticlockwise.

The manufacturers full fitting and adjustment literature are supplied with all door closers.

## Calculating the clear opening

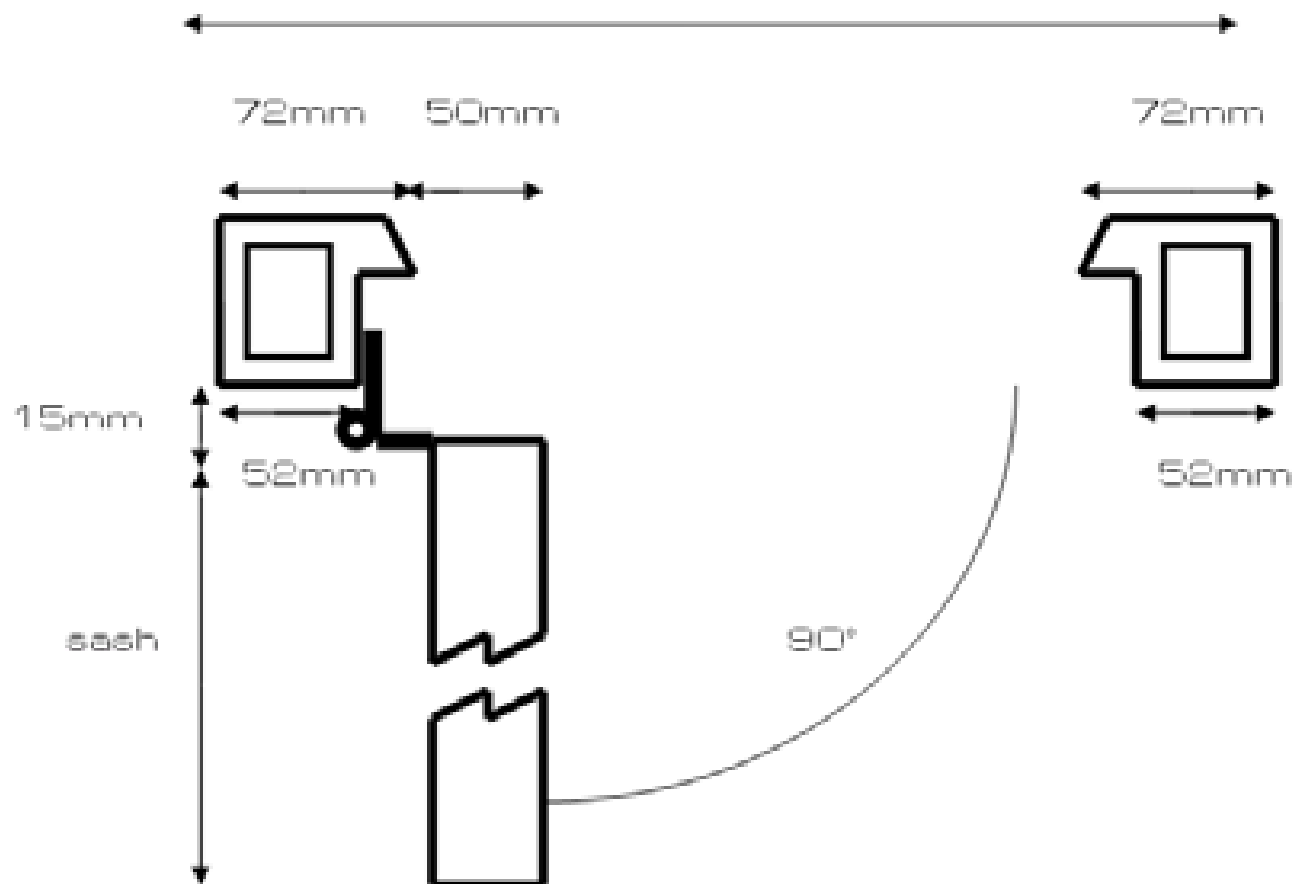

To calculate clear opening:

Overall width - outer (72 or 52) - outer (72 or 52) - sash depth (50mm) document m states this must be more than 780mm on the main entrance.

To calculate internal step clearance:

From external face of profile

Outer frame depth (70mm) + 15mm (for hinge swing) + sash size

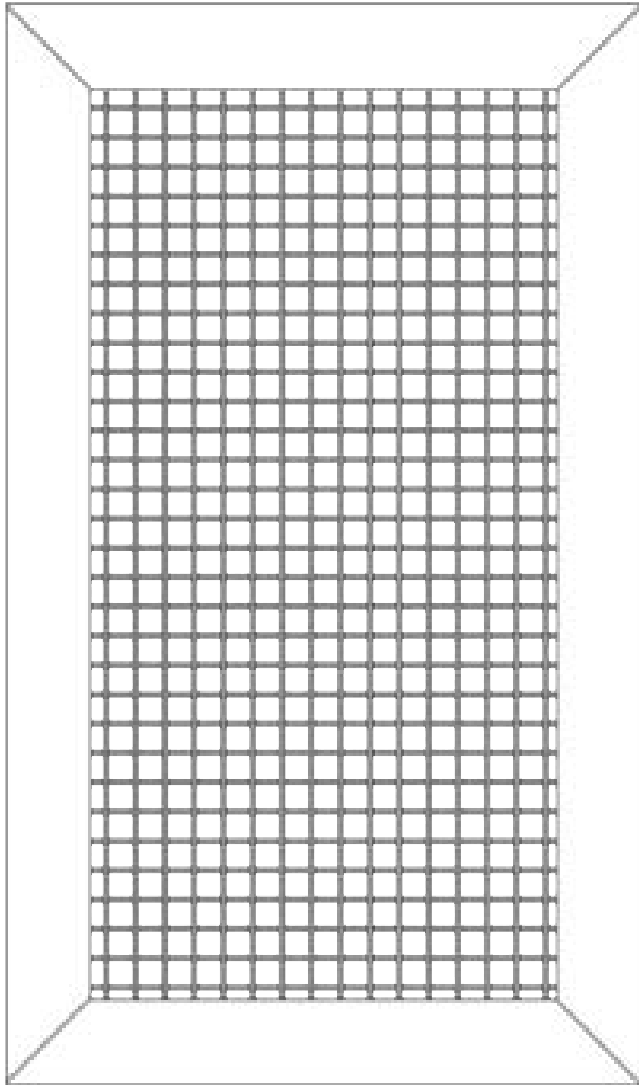

The mesh reinforcement would only be a full sheet if the door had no glass.

### BENEFITS

Makes the door almost impossible to cut through.

### Specification

Heavy gauge galvanised welded steel mesh 20mm x 20mm @ gauge 10g encapsulated in polyurethane foam.

### Feature

The mesh reinforcement combined with the CFC Free core gives extra strength to the door. Rockdoor do not come with security mesh as standard.

## DOUBLE DOORS

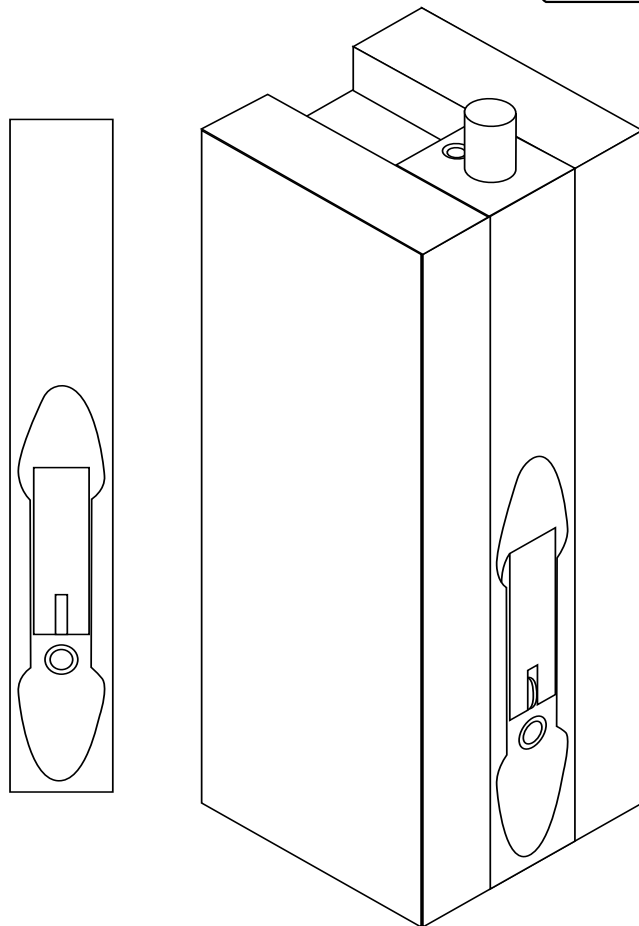
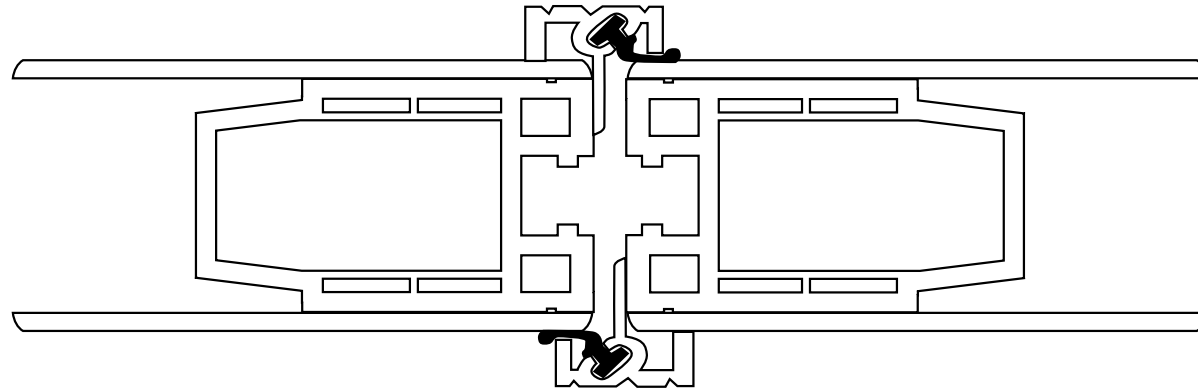

Neat aesthetic appearance.

Concealed screws

Weather engineered seal of tough EPDM rubber cushions door closing.

### BENEFITS FOR SLAVE DOOR

Quick & simple to engage or disengage.

Discreet fitting position.

Works with all Rockdoor lock options.

All Rockdoor styles (Not Stable)  
Open in or out  
All Threshold options

### Locks

Most Rockdoor lock options are available on double doors. Please speak to our sales team for any specific requirements.

### Centre Seals

In addition to our Q-Ion weather seal a special face mounted rebate is fitted both internally & externally.

### Colours

Polished gold  
Brilliant White  
Satin Chrome

### Slave door

Locking is achieved with 2 x 204mm Lever action flush bolts satin-nickel plated. Operated by a sprung action that flicks the bolt in or out of the locked position. The bolt is discreet as it fixes neatly on the eurogroove.

## Escutcheon and Handle Relationship

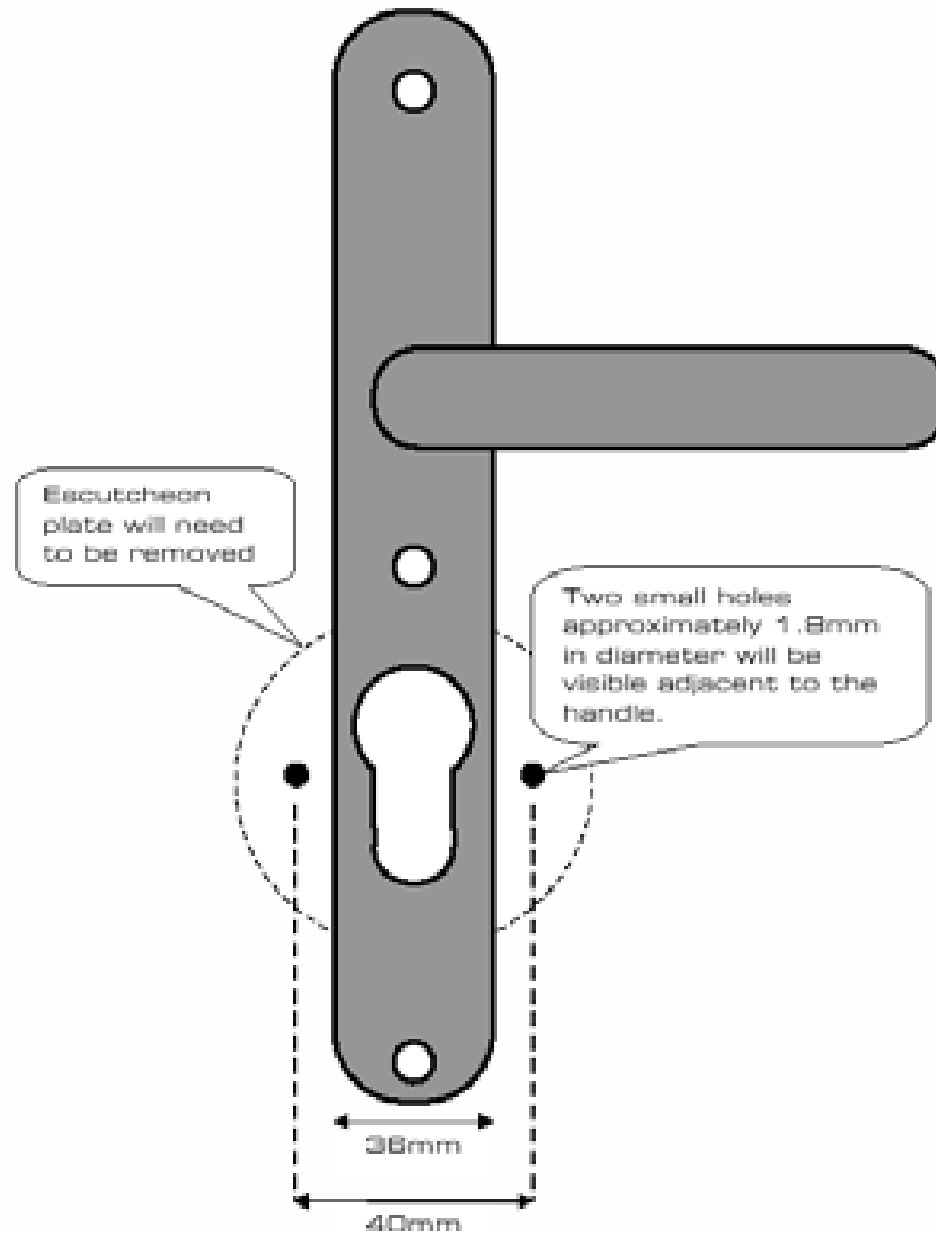

## LOCK EXTRAS

	Open In Door Sets	Open Out Door Sets	Split Spindle	Thumb turn	Key/Key Cylinder	Rim Latch	Electronic Rim Latch Release	Finger Pull	Ball Handle	Lever/Pad Handle
Option 1	☑	☑	☑	☑	STD	☑	☑			☑
Option 2	☑		☑	☑	STD	STD	☑	☑		☑
Option 3	☑	☑	☑	☑	STD	☑	☑	☑		☑
Option 4	☑	☑		STD	☑	☑	☑	☑	☑	
Option 5	☑			STD	☑	STD	☑	STD	☑	
Option 6	☑	☑		STD	☑	☑	☑	☑	☑	
Option 7	☑	☑		STD	STD	☑		☑		
AV2 Option 1	☑	☑		☑	STD				☑	STD
AV2 Option 2	☑	☑		☑	STD				☑	STD
AV2 Option 3	☑	☑		☑	STD				☑	STD
Lock Option 1e	☑	☑	STD	☑	STD					☑
Lock Option 1e/Latch	☑	☑	STD	☑	STD				☑	☑

## Lock Options Explained

### AV2 Option 1 Slam Lock

A mechanical automatic multi-point hook locking system, which throws the hooks as the door is closed without the need to lift the handle manual locking is not necessary. The latch is withdrawn internally by depressing the handle, externally the handle will be fixed, the key unlocks the deadbolt, hooks & the latch. It is recommended that a method of automatically closing the door is fitted with AV2 lock options such as a door closer.

### AV2e Option 2 Slam Lock & Electronic Release

This option operates as AV2 Option 1 with the additional facility of remote electrical release activated with either 3rd party intercom/access controlled switch device (signal must be potential free), radio transmitter device, key fob entry system or a push to release switch. When "mains power failure" emergency conditions occur, emergency exit of the door is achieved by the "crash the handle to open function". Back boxes, switches and relays to be supplied by contractor depending on requirements and site conditions. This lock option is suitable for communal entrances, although key holders can fully dead lock the door which can't be overridden remotely. Wiring diagrams are available.

### AV2e Option 3 Slam Lock, Electronic Release & Battery Back Up

This option operates as AV2 option 1 & AV2e Option 2 with the additional feature of its own independent power supply should "mains power failure" emergency conditions occur, emergency exit of the door can still be achieved by the "crash the handle to open function", but it may also temporarily be released with the use of the connected access system except when the door has been dead-locked.

### Lock Option 1e Electronic Latch Release with Split Spindle

This option operates as Option 1 with a Split Spindle with the additional feature of an electronic latch release fitted to the keep rail on the frame. Entry will only be achievable with the use of a key externally until the hooks and dead bolt have been disengaged this allows the door to be remotely released and pushed open. Nominal voltage 6-12V AC/DC. No wiring is supplied. This option not advisable on communal entrances, it is ideally for single occupancy where the user is has full or at least some mobility.

### Lock Option 1e/latch Electronic Latch Release with Split Spindle

Entry is achieved by use of a key or pushed open when the latch is remotely released. Only suitable for communal entrances or where security & weather performance are not high priority. The door can not be dead locked mechanically. It is recommended that a method of automatically closing the door is fitted with this lock options such as a door closer. 3 keys supplied as standard, additional key blanks available on request.

### Electronic Rim Latch Keep – may be fitted with Rim Latches. (Except on open out door sets)

A fail Locked 12v keep which work in conjunction with the rim latch. No wiring is supplied.



## Lock Options Explained 1

### Option 1 Residential Standard Lever/Handle Operated 2 Hook Lock.

This option allows the opening of the door latch from both the inside and outside by pushing the lever down, the latch will retract and entry or exit can be gained. To lock the door you must lift the lever up to engage the hooks', then turn the key to secure the dead lock from either face.

### Option 2 Residential with Rim Latch Lever/Handle Operated 2 Hook Lock & additional Yale latch.

This option provides the same functionality as option 1. However, the user will require a different key to open and gain access from the outside in addition to the main door lock. The rim latch gives a slam shut facility which can be disengaged by turning the knob on the rim latch and sliding the snib to retain the latch.

### Option 3 Residential Extra Lever/Handle Operated 4 Hook Lock.

This option provides the same functionality as option 1 with the added security and weather performance by the use of two additional hook locking points.

### Option 4 Traditional Standard Key Wind Facility 2 Hook Lock.

No handles are supplied; the hooks are engaged and disengaged by turning the key in the cylinder from the outside & twisting the thumb turn from the inside operating both the latch & hooks the latch. You will need the use of a key to enter and exit the property using this lock option it may be necessary to include a centre knob which can be fitted externally only or internally & externally which will provide a method of pulling the door open or shut. Centre knobs are available in brass or silver.

### Option 5 Traditional with Rim Latch Key Wind Facility 2 Hook Lock & additional Yale latch.

This option provides the same functionality as option 4 however, the user will require a different key to open and gain access from the outside in addition to the standard door lock.

### Option 6 Traditional Extra Key Wind Facility 4 Hook Lock.

This option provides the same functionality as option 4 with the added security and weather performance by the use of two additional hook locking points.

### Option 7 Stable Door Lock.

This option is specifically for stable doors only, therefore it may not be fitted to standard Rockdoor or one of the options 1-6 may not be fitted to a Stable Door.

- Exiting the building. Before you exit the building, please ensure that the top half of the door is secured to the bottom half of the door by throwing the flush mounted door bolt located on the inside of the door. Then with the door closed, the dead bolt and hook are engaged by lifting the handle upward, and then turn the key 360 degrees. The lower half of the door can be dead locked by turning the key or thumb turn 720 degrees. The twisting action of the key or thumb turn, winds out the hook on the lower half of the door. This is the maximum security setting.
- Entering the building. On returning to the building, insert key into lower door cylinder and turn 720 degrees. This will retract the hook back into

## Lock Options Explained 2

the lower half of the door. Then with the same key, insert it into the cylinder in the top half of the door and turn the key 360 degrees. This will unlock the dead bolt and hook. Press down on the handle to retract the dead bolt, hook and door latch. The door can now be opened and entry gained.

- Split door operation. Prior to opening the top half of the stable door you will need to secure the lower half of the door by winding out the hook. This is done by twisting the key or thumb turn 720 degrees. Pull down on the flush mounted door bolt to release the top half from the lower half. Press down on the handle; you should now be able to open the top half of the door

### Optional Extras

Split Spindle - Available with Lock Option 1, 2 & 3.

This function only allows the door to be opened externally with the use of a key.

Thumb Turn - (std on 4, 5, & 6) also available with lock option 1, 2 & 3.

Gold or Silver. This is an alternative cylinder which includes a small knob internally in place of the key making it easier to quickly lock and unlock the door.

Key/Key - (std on 1, 2 & 3) also available with 4, 5 & 6.

Gold or Silver. A cylinder which is operated both internally or externally with the use of a key.

Key Alike - Available with all lock options.

Gold or Silver. This function allows the same key to open all doors fitted with suited cylinders. These cylinders will be supplied separately and will need to be retro-fitted at installation stage.

Rim Latches - (Standard on 2 & 4) also available on 3 & 6. (Except on open out door sets)

Gold Chrome or Silver. A traditional latch which the user will require a different key to open and gain access from the outside in addition to the standard door lock. The rim latch gives a slam shut facility which can be disengaged by turning the knob on the rim latch and sliding the snib to retain the latch.

Finger Pull - (Standard on 5) available with all rim latches.

Gold or Silver. Fitted with a rim latch a finger pull provides a method of pulling the door shut externally.

Lever/Pad Handle - Available with 1, 2, & 3

This is a movable pad handle and will work as a lever/lever handle except when used in conjunction with a split spindle.

Ball Handle - Available with option 4, 5 & 6

Gold or Chrome. Fitted internally only, provides a method of retracting the latch by turning quarter of a turn.

## FIXING INSTRUCTIONS

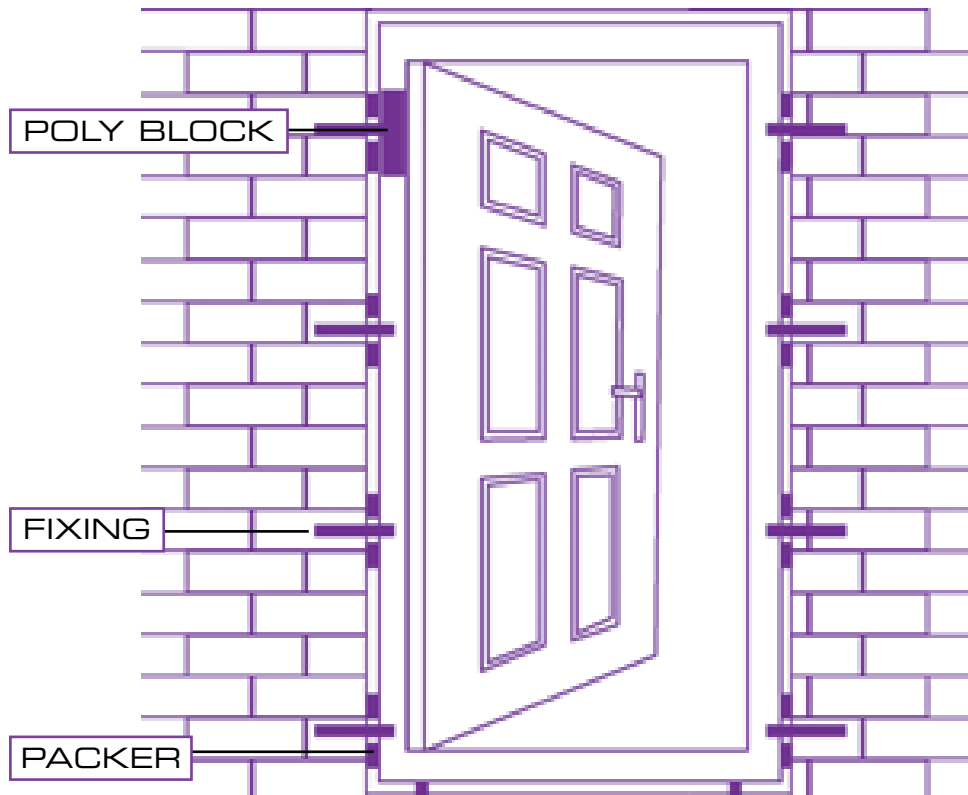

1. Check that the door is the correct size and specification.
2. Remove the old door and frame without damage to brick or plaster.
3. Offer the door and frame into the clean opening.
4. Pack the door frame with an even gap to the verticals, foot and head.
5. Check and adjust if necessary that the threshold is Horizontal
6. Fix the hinge side plumb with four fixings, one fixing must be above the top hinge through the poly block and it must be packed below the bottom hinge as low as possible.
7. Check that the frame is plumb on both the face and the rebate of the frame.
8. Check that the door closes to the lock side and the air gap to the head and jamb is 4mm. Adjust and re-pack the frame if required.
9. Remove the keeps and drill 4 holes through door frame.
10. Check that the door is still flush to the frame and the air gap is 4 mm. Adjust if necessary.
11. Drill the brickwork and fix the lock side of the frame.
12. Replace the keeps covering the fixings.
13. Check the air gap is 4mm to the jamb and head. For fine tuning use the adjustable hinges.
14. Check the door closes, locks, unlocks and adjust compression if necessary.
15. Apply foam to the gap between the frame and brick.
16. Allow the foam to go off.
17. Clean off foam, seal and trim as required.
18. Check door closes, locks and unlocks.
19. Finally, ensure all hinges are fully tightened

# DOOR DIMENSIONS



**2X66 GLAZED**  
Sash size.  
MAX 888 x 2098 MIN 710 x 1755  
Frame size with Threshold. HxW.  
MAX 1000 x 2176 MIN 822 x 1833

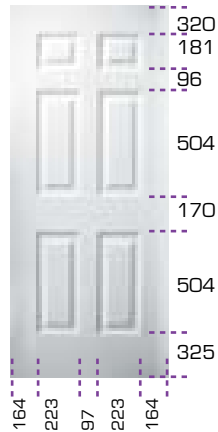

**COLONIAL**  
Sash size.  
MAX 888 x 2098 MIN 753 x 1730  
Frame size with Threshold. HxW.  
MAX 1000 x 2176 MIN 822 x 1833



**COSMOPOLITAN GLAZED**  
Sash size.  
MAX 818 x 2005 MIN 726 x 1736  
Frame size with Threshold. HxW.  
MAX 930 x 2083 MIN 838 x 1814

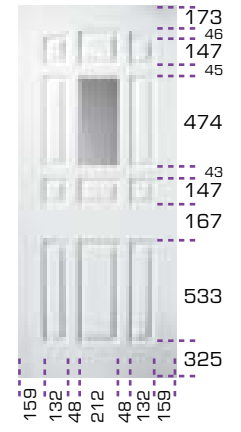

**ELIZABETHAN GLAZED**  
Sash size.  
MAX 888 x 2098 MIN 762 x 1762  
Frame size with Threshold. HxW.  
MAX 1000 x 2176 MIN 874 x 1840



**JACOBAN GLAZED**  
Sash size.  
MAX 888 x 2098 MIN 751 x 1753  
Frame size with Threshold. HxW.  
MAX 1000 x 2176 MIN 863 x 1831

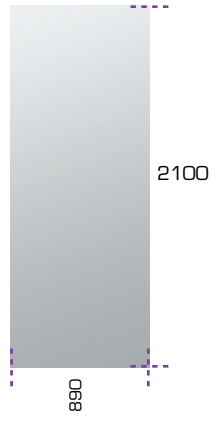

**GRAINED UTILITY DOOR**  
Sash size.  
MAX 888 x 2098 MIN 450 x 1730  
Frame size with Threshold. HxW.  
MAX 1000 x 2176 MIN 562 x 1808

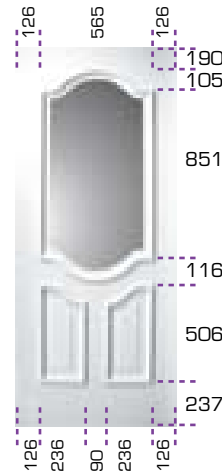

**AYRES GLAZED**  
Sash size.  
MAX 818 x 2005 MIN 742 x 1738  
Frame size with Threshold. HxW.  
MAX 930 x 2083 MIN 854 x 1818

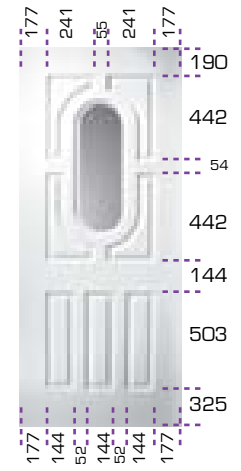

**ARCACIA GLAZED**  
Sash size.  
MAX 888 x 2098 MIN 726 x 1745  
Frame size with Threshold. HxW.  
MAX 1000 x 2176 MIN 838 x 1823

# DOOR DIMENSIONS



**CAROLINA GLAZED**  
Sash size.  
MAX 888 x 2098 MIN 744 x 1730  
Frame size with Threshold. HxW.  
MAX 1000 x 2176 MIN 856 x 1808



**CAROLINA GEO BAR GLAZED**  
Sash size.  
MAX 818 x 2005 MIN 764 x 1730  
Frame size with Threshold. HxW.  
MAX 930 x 2083 MIN 876 x 1808



**CAROLINA BEAD GEO BAR GLAZED**  
Sash size.  
MAX 888 x 2098 MIN 744 x 1730  
Frame size with Threshold. HxW.  
MAX 1000 x 2176 MIN 856 x 1866

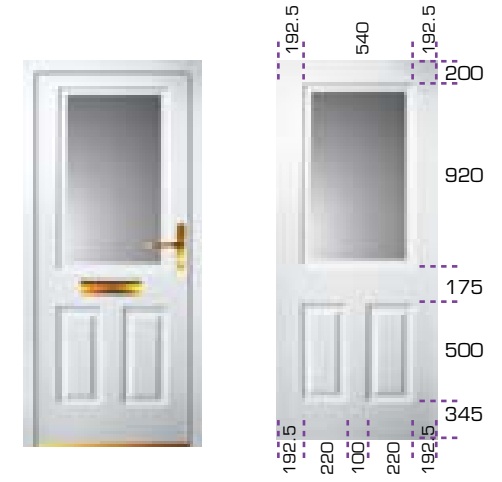

**2xG. GLAZED**  
Sash size.  
MAX 888 x 2098 MIN 742 x 1753  
Frame size with Threshold. HxW.  
MAX 1000 x 2176 MIN 854 x 1831



**COTTAGE SPY VIEW**  
Sash size.  
MAX 888 x 2098 MIN 690 x 1734  
Frame size with Threshold. HxW.  
MAX 1000 x 2176 MIN 802 x 1808



**STABLE SPY VIEW SPLIT**  
Sash size.  
MAX 888 x 2030 MIN 690 x 1657  
Frame size with Threshold. HxW.  
MAX 1000 x 2108 MIN 802 x 1735



**KENTUCKY GEO BAR GLAZED**  
Sash size.  
MAX 888 x 2098 MIN 756 x 1746  
Frame size with Threshold. HxW.  
MAX 1000 x 2176 MIN 868 x 1824



**KENTUCKY NO BAR GLAZED**  
Sash size.  
MAX 888 x 2098 MIN 756 x 1746  
Frame size with Threshold. HxW.  
MAX 1000 x 2176 MIN 868 x 1824

# DOOR DIMENSIONS

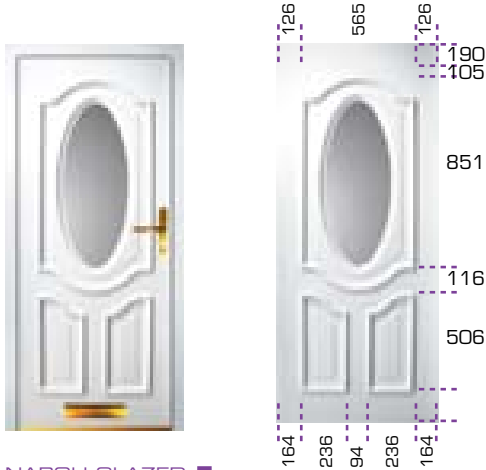

**NAPOLI GLAZED** ■  
Sash size.  
MAX 818 x 2005 MIN 722 x 1738  
Frame size with Threshold. HxW.  
MAX 930 x 2083 MIN 834 x 1816



**REGENCY GLAZED**  
Sash size.  
MAX 888 x 2098 MIN 753 x 1730  
Frame size with Threshold. HxW.  
MAX 1000 x 2176 MIN 865 x 1808



**COTTAGE VIEW LIGHT** ■  
Specification.  
Sash size.  
MAX 888 x 2098 MIN 690 x 1734  
Frame size with Threshold. HxW.  
MAX 1000 x 2176 MIN 802 x 1808



**STABLE VIEW LIGHT SPLIT**  
Specification.  
Sash size.  
MAX 888 x 2030 MIN 690 x 1657  
Frame size with Threshold. HxW.  
MAX 1000 x 2108 MIN 802 x 1735

■ THESE DOORS ARE FACTORY PRESS GLAZED & ARE NONE REGLAZABLE



**TONGUE 'N' GROOVE**  
Specification.  
MAX 888 x 2098 MIN 678 x 1753  
Frame size with Threshold. HxW.  
MAX 1000 x 2176 MIN 830 x 1831

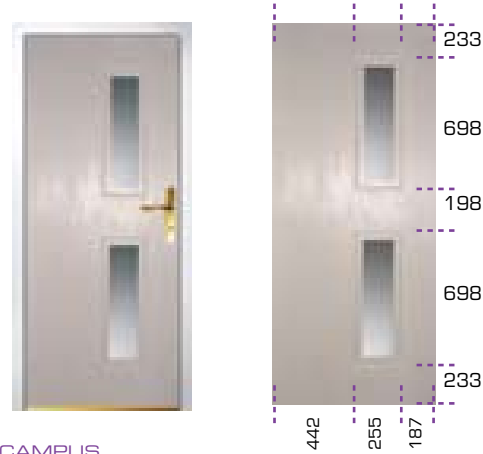

**CAMPUS**  
Sash size.  
MAX 882 x 2058 MIN 710 x 1760  
Frame size with Threshold. HxW.  
MAX 994 x 2136 MIN 822 x 1838

## Double Doors Height as Single Door

Door Styles	Min Width	Max Width
Carolina Geo Bar Glazed	1649	1757
Arcacia	1573	1901
Ayres/Napoli	1605	1757
Elizabethan	1645	1901
Kentucky	1633	1901
Colonial	1627	1901
Jacobean	1623	1901
2xG (Winsor)	1623	1901
Cottage	1501	1901
Cosmopolitan	1573	1757
Carolina Glazed	1609	1901
Jacobean 1/2 door + full door	1264	1431
Jacobean 1/2 door + full door	1432	1501
Glassin 1/2 door off center		

## CYLINDER GUARD

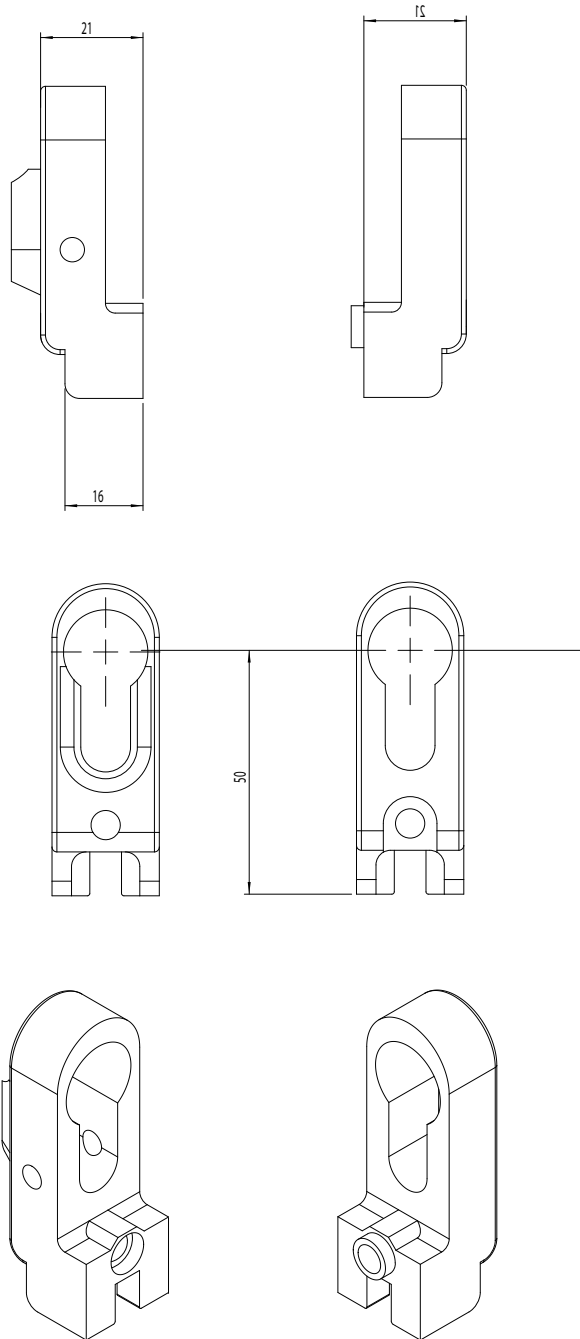

**Cylinder Guard**- designed to withstand extreme attack

Concealed within the internal frame of the rockdoor it shrouds the locking cylinder and protects it from attack from crowbars and large screw drivers.

if the handle is forcefully removed the cylinder guard prevents the potential intruder from snapping the cylinder and gaining entry into the property.

Tested in accordance with A7 heavy duty tools as specified in PAS 24:A.7 security standard

Complies with the latest Police "Secure by Design" guidelines.

## KEEP ADJUSTMENT

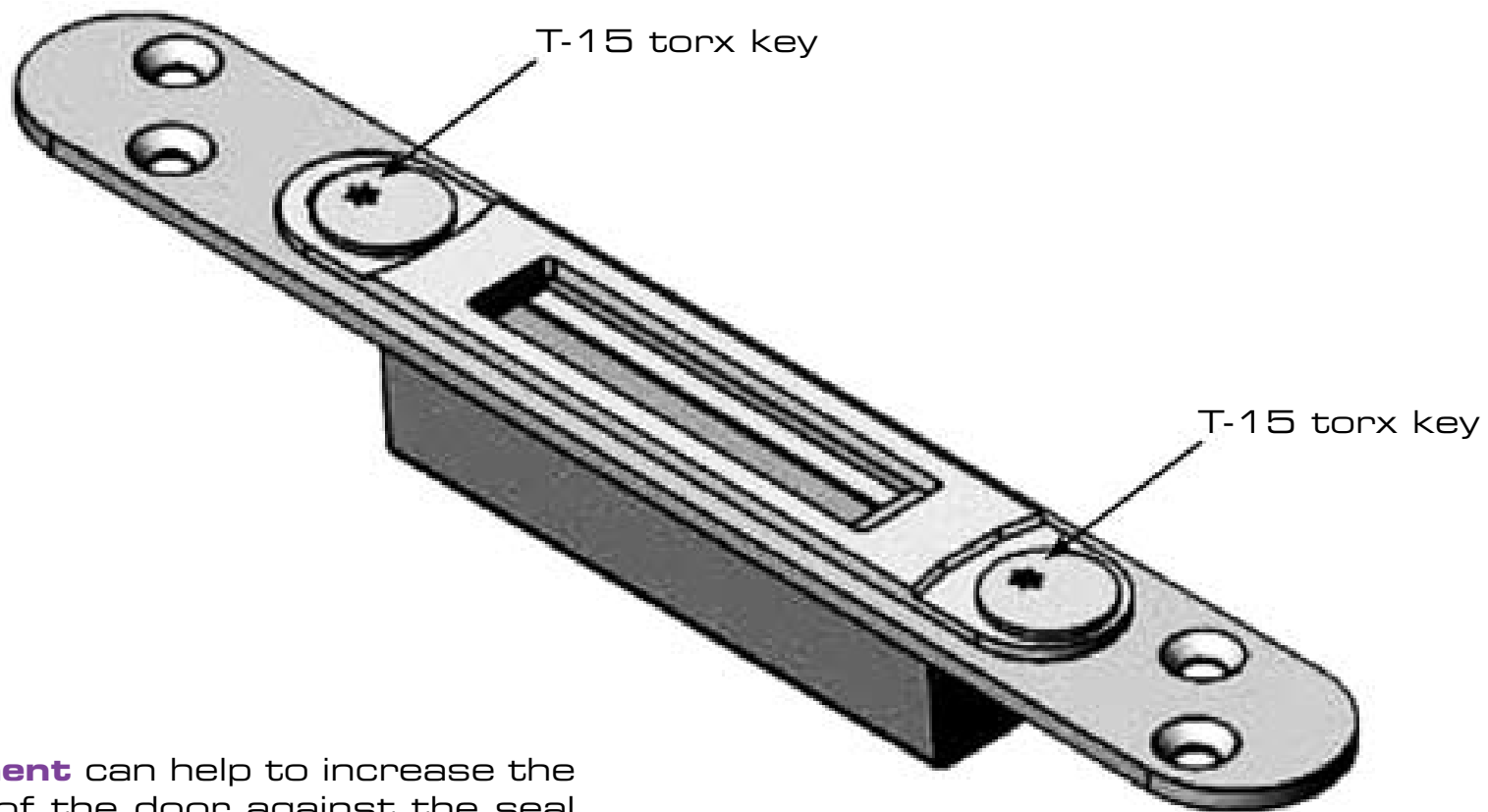

**Keep adjustment** can help to increase the compression of the door against the seal to increase the weather performance, or decrease the compression to make it easier to lock the door. The adjustment of the keep is carried out using a T-15 torx key.