

Xpelair **XID**

Centrifugal metal inline fans



Key features

Application: **Ducted inline ventilation**

Type: **Centrifugal**

Control options: **Speed control and humidity / PIR sensing**



The Range

Inline duct systems have grown in popularity as a method of concealed ducted ventilation over the past two decades. The Xpelair **XID** inline range is engineered for trouble-free operation and delivered complete with adjustable mounting bracket.

These practical, reliable fans are ideal for ducted applications in shops, schools, factories, offices, pubs, hotels, restaurants, and kitchens and are available in a variety of duct size diameters to suit any application.

The range is manufactured in zinc coated corrosion resistant sheet metal with 30mm long spigot connections for ease of connection to ductwork.

The fans are suitable for use in ambient temperatures ranging from -30°C to +50°C. The fan is fully speed controllable using the **XIC1** speed controller.

A full choice of ventilation accessories is available to complement this range to design a complete system.

Specification

Casings

Fan housing is manufactured in two halves from zinc coated sheet steel with formed bellmouth entry and duct attachment spigots 30mm deep.

There are fixings for two universal mounting brackets (supplied) for mounting at any angle and in any plane. The motor support / guide is in zinc coated sheet metal.

Motors and Impellers

Motors are IP44 external rotor type AC capacitor start and run and have maintenance free sealed for life ball bearings. Motor insulation is rated at Class F and motors are fitted with thermal overload protection.

Impellers are backward curved centrifugal, dynamically balanced in two planes to ISO 1940-1 :1986 Grade G.6 suitable for ambient temperatures from -30°C to +50 C

Terminal Box

The terminal box is attached to the casing and also houses capacitor.

Electrical supply 220-240V single phase 50Hz.

The fan is fully speed controllable using the **XIC1** speed controller.



Performance Data

MODEL		XID100	XID125	XID150	XID200	XID250	XID315
Reference number		90101AA	90102AA	90103AA	90104AA	90208AA	90106AA
Spigot diameter (mm)		97	123	147	197	247	312
Airflow (m ³ /s)	0Pa	0.08	0.11	0.17	0.29	0.34	0.46
	100Pa	0.06	0.09	0.12	0.23	0.29	0.41
	200Pa	0.04	0.06	0.07	0.17	0.24	0.35
	300Pa	0.01	0.03	0.02	0.12	0.17	0.28
	400Pa				0.08	0.11	0.22
	500Pa				0.02	0.04	0.16
	600Pa						0.09
	700Pa						0.03
Sound pressure level (dB(A)@3m)		25	26	26	29	32	36
Nominal fan speed (rpm)		2450	2450	2600	2500	2700	2390
Max electrical power (W)		85	85	99	157	194	244
Full load current (A)		0.4	0.4	0.4	0.7	0.8	1.0
Starting current (A)		0.44	0.44	0.62	1.25	1.72	2.82
Motor insulation class		F	F	F	F	F	F
IP rating		IPX4	IPX4	IPX4	IPX4	IPX4	IPX4
Max operating temperature (°C)		50	50	50	50	50	50
Weight (kg)		2.5	2.5	3.7	5	5.6	6.5

Performance Graph

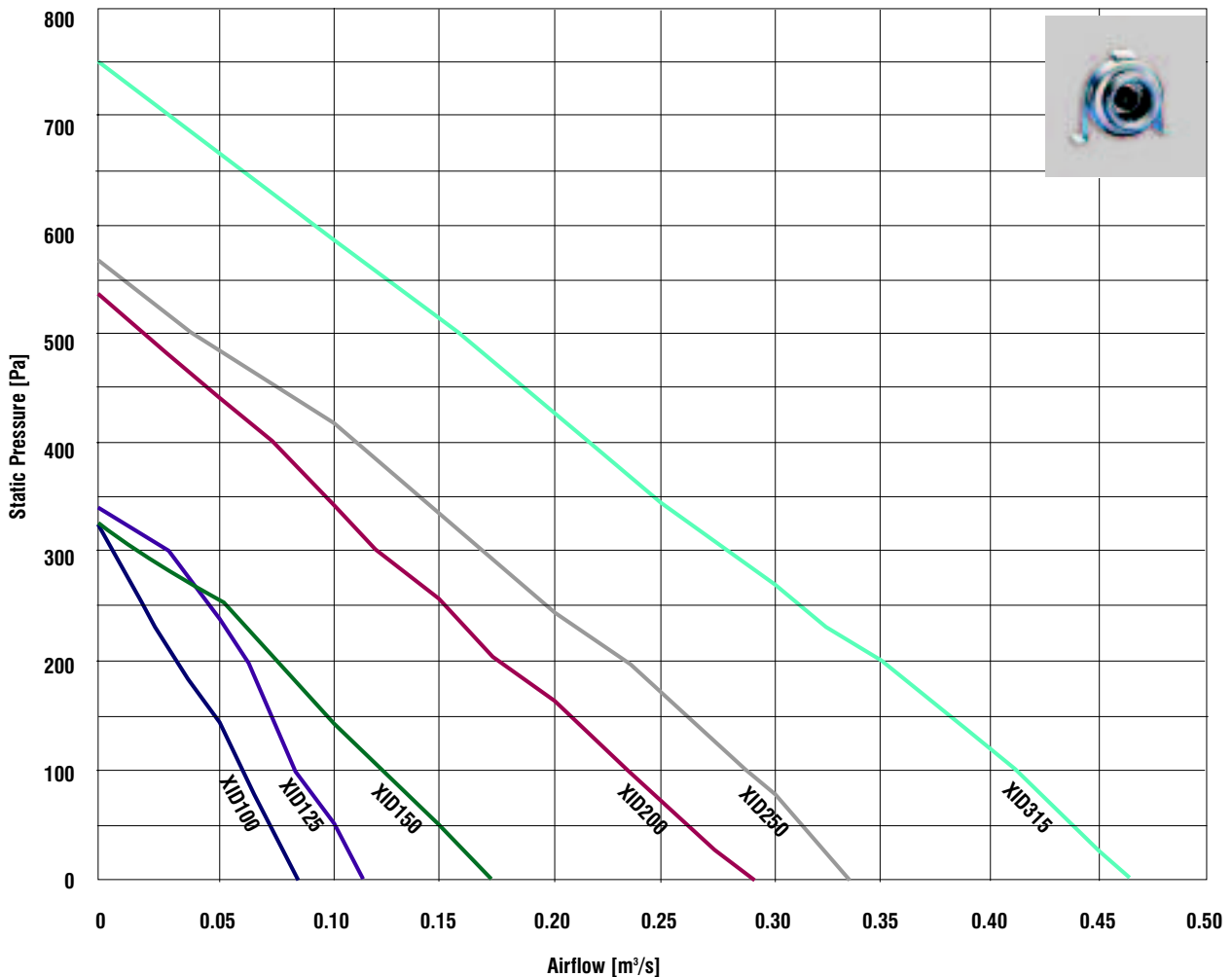

Xpelair **XID**

Centrifugal metal inline fans

Dimensions

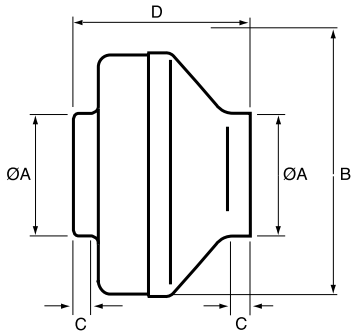

Dimensions (mm)				
Model	A	B	C	D
XID100	97	320	30	240
XID125	123	320	30	240
XID150	147	360	30	250
XID200	197	404	35	250
XID250	247	404	35	260
XID315	312	444	40	260

Installation

An extensive range of accessories are available to complete the installation of the Xpelair **XID** range of inline fans.

The installation diagram shows a typical **XID** ducted installation and associated accessories.

- A** Flexible ducting
- B** Spigot plate
- C** Wall duct
- D** External air operated louvre shutter
- E** Grille box
- F** Ceiling grille
- G** Worm drive clip

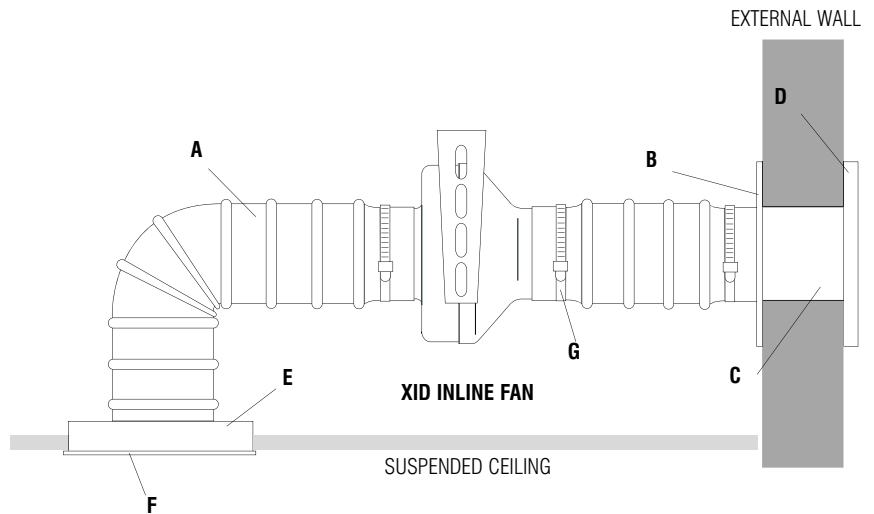

Wiring Diagrams

XID with SCP Starter

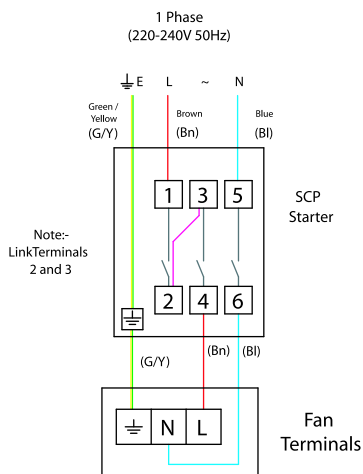

XID with XIC1 speed controller and SCP Starter

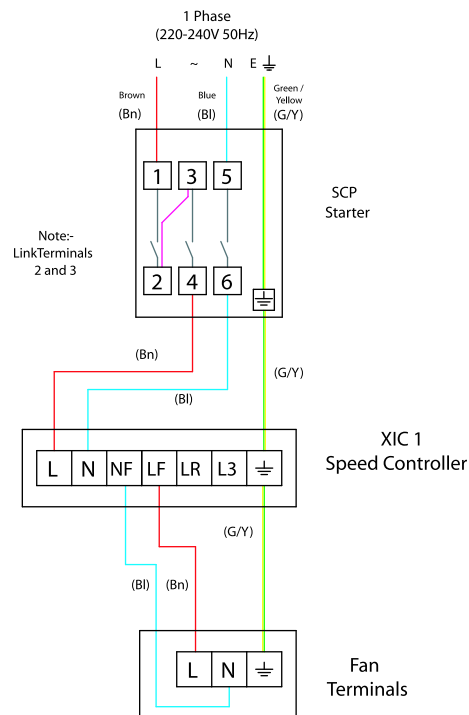



Controllers

				
Model	Inline Fan Controller XIC1	Remote Time Controller DT20B	Remote Humidistat XRH	Passive Infrared Sensor XPIRA
XID100	21858AW	21850AW	21856AW	21871AW
XID125	21858AW	21850AW	21856AW	21871AW
XID150	21858AW	21850AW	21856AW	21871AW
XID200	21858AW	21850AW	21856AW	21871AW
XID250	21858AW	21850AW	21856AW	21871AW
XID315	21858AW	21850AW	21856AW	21871AW

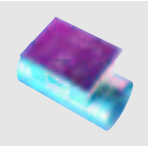
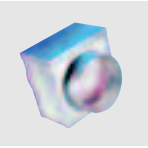
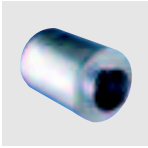
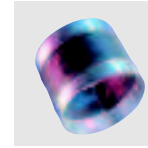
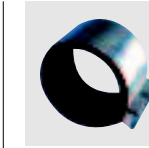
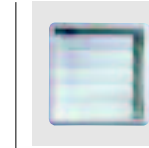
Accessories

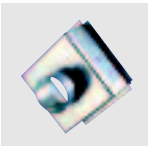
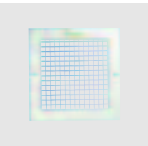
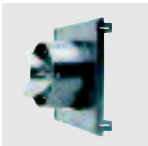
						
Duct Diameter	Inline Duct Heater IDH	Bag Filter Cassette CFC	Circular Silencer SIL	Flexible Connection FFC	Solid Duct Fastener XMK	Louvre Shutter XLG
100mm	90270AA		89837AA		89618AA	89691AA
125mm	90271AA	90285AA	89838AA	90297AA	89619AA	89692AA
150mm	90272AA	90286AA	89839AA	90298AA	89620AA	89693AA
200mm	90273AA	90287AA	89840AA	90299AA	89621AA	89694AA
250mm	90274AA	90288AA	89841AA	90300AA	89622AA	89695AA
315mm	90275AA	90289AA	89842AA	90301AA	89623AA	89696AA

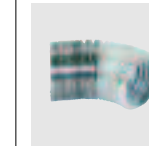
						
Duct Diameter	Grille Box GB	Egg-Crate Ceiling Grille (Silver) CG	Spigot Plate/Damper FWS	Four Way Ceiling Diffuser FW	Circular Air Valve CAV	Aluminium Flexible Ducting Xflex ALU
100mm	89676AA	+ 89675AA			89682AA	91435AA
125mm	89677AA	+ 89675AA			91490AA	91436AA
150mm	89678AA	+ 89675AA	91430AA	+ 91424AA	89683AA	91437AA
200mm	89679AA	+ 89532AA	91431AA	+ 91424AA		91438AA
250mm	89680AA	+ 89532AA	91432AA	+ 91425AA		91439AA
315mm	89681AA	+ 89533AA	91456AA	+ 91426AA		91440AA